



R-Series



Administrator Manual



Digium, Inc.  
445 Jan Davis Drive  
Huntsville, AL 35806  
United States  
Main Number: 1.256.428.6000  
Tech Support: 1.256.428.6161  
U.S. Toll Free: 1.877.344.4861  
Sales: 1.256.428.6262  
[www.digium.com](http://www.digium.com)  
[www.asterisk.org](http://www.asterisk.org)  
[www.asterisknow.org](http://www.asterisknow.org)

© Digium, Inc. 2012  
All rights reserved.

No part of this publication may be copied, distributed, transmitted, transcribed, stored in a retrieval system, or translated into any human or computer language without the prior written permission of Digium, Inc.

Digium, Inc. has made every effort to ensure that the instructions contained in this document are adequate and error free. The manufacturer will, if necessary, explain issues which may not be covered by this documentation. The manufacturer's liability for any errors in the documents is limited to the correction of errors and the aforementioned advisory services.

This document has been prepared for use by professional and properly trained personnel, and the customer assumes full responsibility when using it.

R-Series software is built using FreeRTOS under the terms of GPL2 as stated at <http://www.freertos.org/a00114.html>. Digium will provide the FreeRTOS source code upon request.

Adobe and Acrobat are registered trademarks, and Acrobat Reader is a trademark of Adobe Systems Incorporated.

Asterisk, Digium, Switchvox, and AsteriskNOW are registered trademarks and Asterisk Business Edition, AsteriskGUI, and Asterisk Appliance are trademarks of Digium, Inc.

Any other trademarks mentioned in the document are the property of their respective owners.

## Safety Certification and Agency Approvals

### Safety:

UL/CSA 60950-1 2nd Ed.

IEC 60950-1:2005 (2nd Ed.) +A1:2009

EN 60950-1:2006 (2nd Ed.) +A11:2009 +A1:2010

AS/NZS 60950-1 1st Ed.

**Note:** Finland, Norway and Sweden require that equipment using this product must be located in a Restricted Access Location (RAL).

### Other:

CE Mark (European Union)

2002/95/EC Restrictions on Hazardous Substances (RoHS), 2005/747/EC lead free exemption (Annex C)

### EMC:

47 CFR Part 15, Subpart B / 47 CFR Part 15, Subpart B, Class A

EN55022:2010 IEC CISPR22:2009 Class A

IEC 61000

EN 61000-3-2:2006 +A1 & A2

EN 61000-3-3:2008

EN 55024:2010

CNS13438:2006

VCCI V-3 2010.04

## **FCC Part 15**

This device complies with part 15 of FCC rules. Operation is subject to the following two conditions: (1) This device may not cause harmful interference, and (2) This device must accept any interference received, including interference that may cause undesired operation.

## Introduction to R-Series Documentation

This manual contains product information for the R-Series units. Be sure to refer to any supplementary documents or release notes that were shipped with your equipment. The manual is organized in the following manner:

<b>Chapter/ Appendix</b>	<b>Title</b>	<b>Description</b>
<b>1</b>	Overview	Identifies the features of your unit.
<b>2</b>	Unit Installation	Provides instructions for installing the unit.
<b>3</b>	Configuration	Provides instructions on how to configure the unit.
<b>4</b>	Troubleshooting	Explains resolutions to common problems and frequently asked questions pertaining to unit installation and usage.
<b>A</b>	State Descriptions	Describes the states supported by the unit.
<b>B</b>	Pin Assignments	Lists the connectors and pin assignments.
<b>C</b>	License Agreement	Digium End-User Purchase and License Agreement
<b>D</b>	Glossary and Acronyms	Defines terms related to this product.

## Symbol Definitions



*Caution statements indicate a condition where damage to the unit or its configuration could occur if operational procedures are not followed. To reduce the risk of damage or injury, follow all steps or procedures as instructed.*



*The ESD symbol indicates electrostatic sensitive devices. Observe precautions for handling devices. Wear a properly grounded electrostatic discharge (ESD) wrist strap while handling the device.*



*The Electrical Hazard Symbol indicates a possibility of electrical shock when operating this unit in certain situations. To reduce the risk of damage or injury, follow all steps or procedures as instructed.*

## Important Safety Instructions



### **Servicing.**

*Do not attempt to service this unit unless specifically instructed to do so. Refer servicing to qualified service personnel.*



### **Water and Moisture.**

*Do not spill liquids on this unit. Do not operate this equipment in a wet environment.*



### **Heat.**

*Do not operate or store this product near heat sources such as radiators, air ducts, areas subject to direct, intense sunlight, or other products that produce heat.*



### **Caution.**

*To reduce the risk of fire, use only No. 26 AWG or larger telecommunication wiring for network connections.*



### **Static Electricity.**

*To reduce the risk of damaging the unit or your equipment, do not attempt to open the enclosure or gain access to areas where you are not instructed to do so. Refer servicing to qualified service personnel.*

**Save these instructions for future reference.**

---

# TABLE OF CONTENTS

---

## Chapter 1

<b>Overview</b>	<b>12</b>
What is Asterisk®?	14
Asterisk as a Phone Switch (PBX)	14
Asterisk as a Gateway	14
Asterisk in the Call Center	15
Asterisk in the Network	15
Asterisk Everywhere	16

## Chapter 2

<b>Unit Installation</b>	<b>17</b>
Unpacking the Unit	18
Shipment Inspection	19
Front Panel Identification	20
Unit Identification	23
USB Requirements	24
Hardware Installation	25
Software Installation	30

## Chapter 3

<b>Configuration</b>	<b>32</b>
Understanding Serial Device Assignments	33
R-Series Control Utility	34
Automatic Failover Configuration	39

**Chapter 4**

**Troubleshooting . . . . .81**

    Terminal Emulation Program Setup . . . . .82

    ASCII Mode . . . . .87

    R-Series Command-line Utility . . . . .94

    Frequently Asked Questions . . . . .99

    Free Installation Support . . . . .104

    Subscription Services Program . . . . .104

**Appendix A**

**State Descriptions . . . . .105**

**Appendix B**

**Pin Assignments . . . . .108**

**Appendix C**

**License Agreement . . . . .111**

**Appendix D**

**Glossary and Acronyms . . . . .123**

Figure 1:	Basic Application Sequence . . . . .	13
Figure 2:	R800 Analog Unit . . . . .	20
Figure 3:	R850 Digital Unit . . . . .	20
Figure 4:	Automatic Failover Scenario . . . . .	40
Figure 5:	Minicom Main Menu . . . . .	83
Figure 6:	Minicom Serial Port Setup . . . . .	84
Figure 7:	Minicom Save as Default . . . . .	84
Figure 8:	Minicom Exit . . . . .	85
Figure 9:	ASCII Mode Menu for Analog . . . . .	89
Figure 10:	ASCII Mode Menu for Digital . . . . .	91
Figure 1:	Input to Primary State . . . . .	105
Figure 2:	Input to Secondary State . . . . .	106
Figure 3:	Loopback State . . . . .	107

Table 1:	R-Series Models . . . . .	23
Table 2:	Unit Identifiers . . . . .	29
Table 1:	Resource Management . . . . .	45
Table 2:	Resource Configuration . . . . .	76
Table 3:	Terminal Emulation Settings . . . . .	82
Table 1:	ASCII Mode Keyboard Command List . . . . .	87
Table 2:	R-Series Command-line Utility . . . . .	94
Table B-1:	RJ11 Port Connector . . . . .	108
Table B-2:	RJ45 Port Connector . . . . .	110

# Chapter 1

## Overview

---

The Digium Redundancy Series of products, R-Series, are versatile devices used to facilitate physical layer switching of PSTN interfaces for Asterisk based redundant PBX configurations. R-Series is among several key technologies Digium is introducing to empower Asterisk integrators to create advanced high-reliability failover solutions.

The basic application sequence shown below depicts the following:

1. While in a normal state, the R-Series unit routes the input lines from the PSTN to Server A (*Primary*).
2. After a failure of Server A, the R-Series unit routes the input lines from the PSTN to Server B (*Secondary*).
3. After Server A recovers, the R-Series unit continues to route the input lines from the PSTN to Server B.
4. After a failure of Server B, the R-Series unit routes the input lines from the PSTN to Server A.

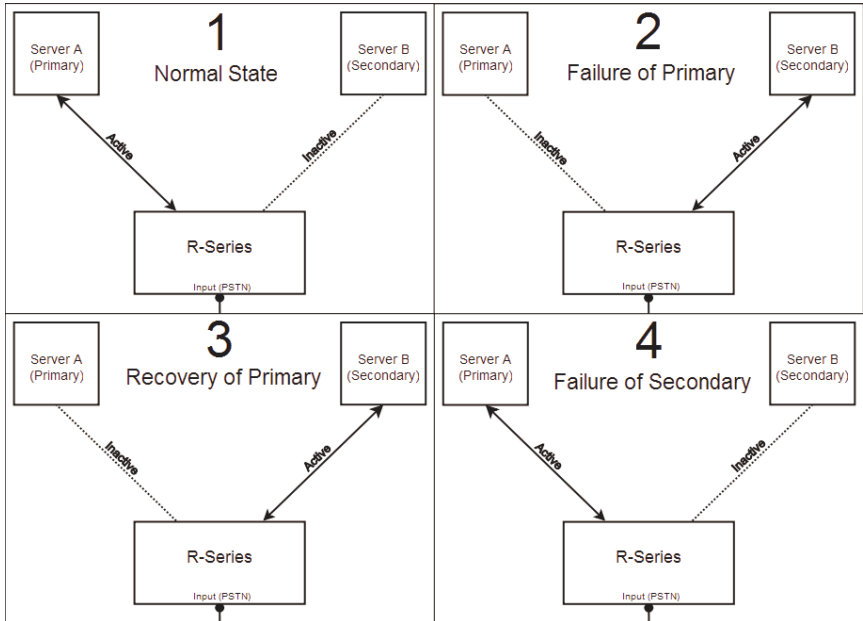

**Figure 1: Basic Application Sequence**

There are a variety of applications where the R-Series units can prove useful.

### What is Asterisk®?

Asterisk is the world's leading open source telephony engine and tool kit. Offering flexibility unheard of in the world of proprietary communications, Asterisk empowers developers and integrators to create advanced communication solutions...for free. Asterisk is released as open source under the GNU General Public License (GPL), and it is available for download free of charge. Asterisk is the most popular open source telephony software available, with the Asterisk Community being the top influencer in VoIP.

### Asterisk as a Phone Switch (PBX)

Asterisk can be configured as the core of an IP or hybrid PBX, switching calls, managing routes, enabling features, and connecting callers with the outside world over IP, analog (POTS), and digital (T1/E1/J1/BRI) connections.

Asterisk runs on a wide variety of operating systems including Linux, Mac OS X, OpenBSD, FreeBSD, and Sun Solaris. It provides all of the features you would expect from a PBX including many advanced features that are often associated with high end (and high cost) proprietary PBXs. Asterisk's architecture is designed for maximum flexibility and supports Voice over IP in many protocols, and can interoperate with almost all standards-based telephony equipment using relatively inexpensive hardware.

### Asterisk as a Gateway

It can also be built out as the heart of a media gateway, bridging the legacy PSTN to the expanding world of IP telephony. Asterisk's modular

architecture allows it to convert between a wide range of communications protocols and media codecs.

### **Asterisk as a Feature/Media Server**

Need an IVR? Asterisk's got you covered. How about a conference bridge? Yep. It's in there. What about an automated attendant? Asterisk does that too. How about a replacement for your aging legacy voicemail system? Can do. Unified messaging? No problem. Need a telephony interface for your web site? Okay.

### **Asterisk in the Call Center**

Asterisk has been adopted by call centers around the world based on its flexibility. Call center and contact center developers have built complete ACD systems based on Asterisk. Asterisk has also added new life to existing call center solutions by adding remote IP agent capabilities, advanced skills-based routing, predictive and bulk dialing, and more.

### **Asterisk in the Network**

Internet Telephony Service Providers (ITSPs), Competitive Local Exchange Carriers (CLECs) and even first-tier incumbents have discovered the power of open source communications with Asterisk. Feature servers, hosted services clusters, voicemail systems, and pre-paid calling solutions, all based on Asterisk have helped reduce costs and enabled flexibility.

## **Asterisk Everywhere**

Asterisk has become the basis for thousands of communications solutions. If you need to communicate, Asterisk is your answer. For more information on Asterisk, visit <http://www.asterisk.org> or <http://www.digium.com>.

## Chapter 2

### Unit Installation

---

This chapter provides the following information:

- **Unpacking the Unit** on page 18
- **Shipment Inspection** on page 19
- **Front Panel Identification** on page 20
- **Unit Identification** on page 23
- **USB Requirements** on page 24
- **Hardware Installation** on page 25
- **Software Installation** on page 30

**Note:** The R-Series unit installation instructions are written so that they will apply to any model in the series. Examples and model specific information are included as needed.

### Unpacking the Unit

When you unpack your unit, carefully inspect it for any damage that may have occurred in shipment. If damage is suspected, file a claim with the carrier and contact the reseller from which the unit was purchased. If the unit was purchased direct from Digium, contact Digium Technical Support at +1.256.428.6161. Keep the original shipping container to use for future shipment or proof of damage during shipment.

**Note:** Only qualified service personnel should install the unit. Users should not attempt to perform this function themselves. The installer must ensure that the equipment is reliably earth grounded in accordance with the National Electrical Code.



*This unit is intended for installation in a Restricted Access Location (RAL) only.*

### Shipment Inspection

The following items are included in shipment of an R-Series unit:

- R-Series unit
- Two USB A-B cables
- Rack mounting ears and four screws
- Ground nut
- Ground ring terminal
- Warranty Statement
- Quickstart Guide

**Note:** After inspecting the shipment, Digium highly recommends that you register the unit for support eligibility. Please refer to **Free Installation Support** on page 104 for additional information on how to obtain assistance from Digium Technical Support.

### Front Panel Identification

This section describes the components on the front panels of the various R-Series models.

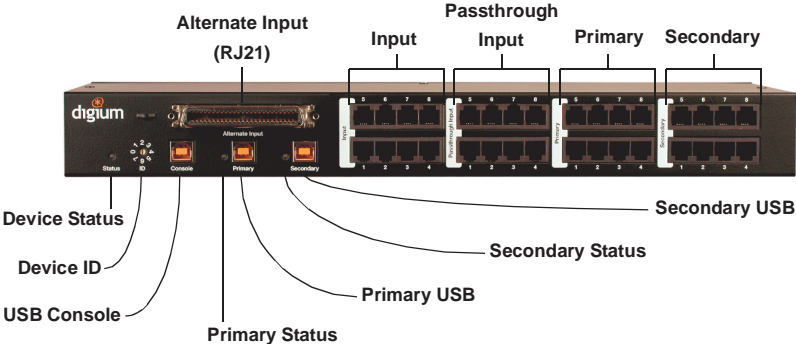

Figure 2: R800 Analog Unit

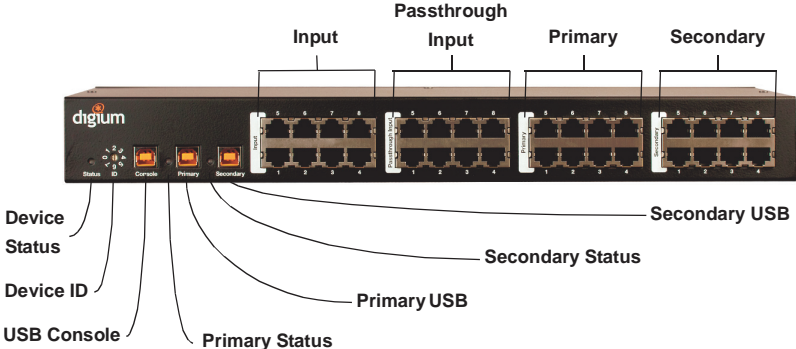

Figure 3: R850 Digital Unit

- **Alternate Input (optional)** - Provides an alternate method for connecting input lines using an RJ21 interface and is available only on some analog models.
  - Note:** The *Alternate Input* and *Input* connectors should not have lines connected to them at the same time.
- **Input** - These ports are used for connecting input lines, such as those coming from the PSTN. A cable can be connected from each of these ports to an input line. Digital models use an RJ45 interface. Analog models use an RJ11 interface.
- **Passthrough Input (optional)** - These ports are generally connected to the primary PBX for the purpose of front-ending a legacy PBX connected to secondary ports. A cable can be connected from each of these ports to a separate port on the primary PBX. Digital models use an RJ45 interface. Analog models use an RJ11 interface.
  - Note:** The Passthrough Input is reserved for future use.
- **Primary** - These ports are used for routing the input lines to the primary PBX. A cable can be connected from each of these ports to a separate port on the primary PBX. Digital models use an RJ45 interface. Analog models use an RJ11 interface.
- **Secondary** - These ports are used for routing the input lines to the secondary PBX. A cable can be connected from each of these ports to a separate port on the secondary PBX. Digital models use an RJ45 interface. Analog models use an RJ11 interface.
- **Device Status** - This LED corresponds to the status of the R-Series unit. See **Troubleshooting** on page 81 for more information.
- **Device ID** - This dial should be set to a number which is unique across all R-Series units that co-exist in an installation. The Device ID assignment for your first device should be 0, second device should be 1, third device should be 2, and so on.

- **USB Console** - This port can be used to access unit status, system information, power the R-Series unit, and perform maintenance operations in ASCII Mode without disconnecting the *Primary USB* or *Secondary USB* ports. A USB A-B cable may be connected from this port to a USB port on a computer. See **ASCII Mode** on page 87 for more information.

**Note:** Any of the USB ports can be operated in ASCII Mode.

- **Primary Status** - This LED corresponds to the status of the *Primary* connection made on *Primary USB*. See **Troubleshooting** on page 81 for more information.
- **Primary USB** - This port is used for communicating with the *Primary* PBX, powering the R-Series unit, and accessing ASCII Mode. A USB A-B cable should be connected from this port to a USB port on the *Primary* PBX. See **ASCII Mode** on page 87 for more information.
- **Secondary Status** - This LED corresponds to the status of the *Secondary* connection made on *Secondary USB*. See **Troubleshooting** on page 81 for more information.
- **Secondary USB** - This port is used for communicating with the *Secondary* PBX, powering the R-Series unit, and accessing ASCII Mode. A USB A-B cable should be connected from this port to a USB port on the *Secondary* PBX. See **ASCII Mode** on page 87 for more information.

## Unit Identification

The defining characteristics of the R-Series models are whether the unit supports analog or digital lines, the number of ports supported, whether the unit includes a Passthrough connector, and whether the unit supports RJ21 for an alternate input method. See Table 1 for a list of the various models.

**Table 1: R-Series Models**

Model	Type	Ports	Passthrough	RJ21 Input
R800	POTS	8	Yes	Yes
R850	T1/E1/BRI	8	Yes	Not Applicable

**Note:** Passthrough is reserved for future use.



### Caution

*Only qualified service personnel should continue with hardware installation and configuration of the R-Series unit. Users should not attempt to perform these functions themselves.*

### USB Requirements

The servers which connect to an R-Series unit using the *USB Console*, *Primary USB*, and *Secondary USB* ports must support USB 1.1 or greater for compatibility. If either server does not support at least USB 1.1, an R-Series unit will not work.

### Hardware Installation

This section describes how to properly install the hardware for an R-Series unit.

#### Grounding

The R-Series unit must be properly grounded for safety reasons. If the unit is not properly grounded, damage could arise to the R-Series unit and/or other equipment connected to the R-Series unit. If an R-Series unit is damaged while it is improperly grounded, the warranty on the R-Series unit is void.

A ground lug is located on the opposite side from the front panel of an R-Series unit. Attach an appropriate length and gauge of wire to the ground ring terminal. The wire length should be as short as possible, and gauge should be 18 AWG or greater. Stranded or solid wire is acceptable. Wire is not provided with the R-Series unit. Slide the ground ring terminal over the ground lug. Then fasten the ground ring terminal to the ground lug using the ground nut. The ground nut must be turned clockwise to tighten it onto the ground lug. The opposite end of the wire that is connected to the ground ring terminal should be securely fastened to an unpainted metallic section of a properly grounded server rack. A connector for the opposite end of the wire is not provided with the R-Series unit.

**Note:** Taking into consideration the requirements of all equipment that is connected to or sharing the rack, the server rack should be properly grounded. Refer to the manufacturer of the rack for instructions on how to properly ground the rack.

### Mounting

Place one of the rack mounting ears on the right side of the R-Series unit. Line up the holes from the rack mountings ear to the threaded holes on the side of the R-Series unit. Two screws should be inserted and turned clockwise to fasten the rack mounting ear. Repeat these steps when installing a rack mounting ear on the left side of the R-Series unit.

A typical equipment rack installation would have an R-Series unit mounted on the opposite side of the rack as the servers. Use 2 screws on each rack mounting ear to secure the R-Series unit to a rack.

### Setting Device ID Dial

The Device ID dial should be set to a number which is unique across all R-Series units that co-exist in an installation. The Device ID assignment for your first device should be 0, second device should be 1, third device should be 2, and so on.

### Connecting Ports (Powering the Unit)

A description of each of the front panel connectors on an R-Series unit is available in the section titled **Front Panel Identification** on page 20. Please refer to that section to determine what should be connected to each connector.

Connections to an R-Series unit should be made in the following order.

1. *Primary*
2. *Secondary*

3. *Passthrough Input* (optional) - Reserved for future use.
4. *Input or Alternate Input* (not both)
5. *Primary USB*
6. *Secondary USB*
7. *USB Console*

An R-Series unit will receive power from any of the three USB connections (*USB Console, Primary USB, Secondary USB*). No other power source is required.

**Note:** You may have to apply a decent amount of force to disconnect a USB cable from an R-Series unit. This is normal. The USB connectors used in the R-Series units are high-retention to help prevent accidental disconnection.

### General Recommendations

Using an R-Series unit in conjunction with a USB hub may have undesirable results.

Each server connected to an R-Series unit should be powered from a different power source.

It is highly recommended that each server connected to an R-Series unit be equipped with sufficient surge protection to reduce the risk of damage to the server and R-Series unit.

It is recommended that each server which is connected to an R-Series unit be equipped with an uninterruptible power supply that has sufficient reserve capacity to power the server until electricity is restored. A generator may also be used as an alternate means of powering the servers while mains power is out.



### Caution

*This unit must be connected to the Telecommunications Network in your country using an approved line cord, e.g.: for Australia use only line cords complying with ACA Technical Standard TS008.*



### Caution

*Connect only equipment approved for use in your specific country to the telecommunications network voltage circuit ports.*

## Verification

**Note:** The following steps need to be performed on all Asterisk nodes which are connected to an R-Series unit. In addition, all command-line applications mentioned in this manual must be executed as the root user.

Log in and execute the following command to list the devices detected by the USB controller:

```
# lsusb
```

Confirm that the output from **lsusb** lists a device with a USB vendor ID of “10c4”. The screen output should be similar to the following:

```
Bus 003 Device 002: ID 10c4:<device identifier>  
Cygnal Integrated Products, Inc. CP210x Composite  
Device
```

In the USB device listing shown above, <device identifier> will be populated with one of the identifiers listed in the table below.

**Note:** Unit identifiers are the same for all R-Series models.

**Table 2: Unit Identifiers**

<b>Model</b>	<b>Identifier</b>
R800	ea60
R850	ea60

A Digium R-Series (R800 / R850) unit identifier should be listed. If a matching unit identifier is not listed, then your machine is not USB 1.1 (or higher), and the unit will not work with your motherboard.

### Software Installation

While the R-Series units do not require DAHDI drivers in order to function, DAHDI drivers and other libraries may need to be installed in order for other Digium hardware products to function when connected to an R-Series unit.

Digium hardware which relies on DAHDI requires drivers and libraries that are not integrated with the Linux kernel. Digium hardware is only supported under Linux. Digium recommends CentOS, Debian, Red Hat, and Ubuntu distributions of Linux. However, many other distributions are supported by Digium Technical Support.

Digium's software, including drivers and application software, may be obtained from Digium's download servers at:

<http://downloads.digium.com>

<http://downloads.asterisk.org>

For an introduction to Asterisk, Digium's telephony software, including additional information on its configuration, setup, and features, please refer to:

<http://www.asterisk.org>

For the latest information on setting up and configuring DAHDI drivers for your Digium hardware products, please refer to the latest release of your products' manuals which are available from the product-specific documentation section at:

<http://www.digium.com>

To install your R-Series unit for use with other Digium hardware that relies on DAHDI, you will need:

- Linux 2.6 kernel headers
- Development libraries and headers for ncurses
- Development libraries and headers for zlib and openssl
- Development libraries and headers for newt
- GCC and standard software build tools
- Subversion
- Terminal emulation program such as Minicom (optional)

It is recommended that you use the most recent version of the Asterisk software for the best results. If you have previously installed this, Digium recommends that you upgrade to the latest “-current” version.

Additional software installation steps are described in **Chapter 3—“Configuration”**.

## Chapter 3

# Configuration

---

The R-Series units have a variety of configuration options. This chapter provides sample configurations to demonstrate customizing the unit to meet your individual needs. Each section explains basic options as examples. Once you have familiarized yourself with the examples, you can modify them to meet your specific needs.

## Understanding Serial Device Assignments

When the *Console*, *Primary*, or *Secondary* USB ports on the R-Series unit are connected to a system, a device file associated with the R-Series unit should automatically be created that is visible from the filesystem of that system. In most cases, the default device file assignment for the first serial device connected over USB is *ttyUSB0* in the */dev* directory. The second serial device connected over USB is *ttyUSB1*, and so on. This does not correlate to the Device ID Dial setting of the R-Series unit. It is important to know the device file assignment of the R-Series unit that is being configured.

**Note:** During installation of the R-Series command-line utility, *rctl*, *udev* rules will be installed which will automatically map the R-Series unit's device file of */dev/ttyUSB[#]* to */dev/rseries[#]*. For */dev/rseries[#]*, the # is the Device ID Dial assignment of the R-Series unit. For example, an R-Series unit with a Device ID Dial assignment of 0 will have a device file associated at */dev/rseries0*. We **highly recommend** referencing */dev/rseries[#]* instead of */dev/ttyUSB[#]* where possible. The *rctl* utility will be installed at a later point in the manual.

## R-Series Control Utility

Digium provides the source code for the R-Series control utility. This software should be installed on both the primary and secondary node. In the examples shown throughout this manual, substitute the X.X.X in rseries-X.X.X with the version of the R-Series source package.

```
# cd /usr/src
# wget http://downloads.digium.com/pub/telephony/
rseries/rseries-current.tar.gz
# tar zxvf rseries-current.tar.gz
# cd rseries-X.X.X
# make
# make install
```

## Basic Functional Testing

Execute the following commands to query basic information from the R-Series unit.

```
# cd /usr/src/rseries-X.X.X/
# ./rtest.sh info /dev/rseries [#]
```

Output similar to the following is normal after executing this command.

```
R-Series hardware is detected!  
Firmware version: 4  
Serial number: DM*****  
Product number: R850  
Ports: 8  
ID Switch: 0  
Watchdog Timeout (get): 129  
Port 1: 0, primary, T1/E1  
Port 2: 0, primary, T1/E1  
Port 3: 0, primary, T1/E1  
Port 4: 0, primary, T1/E1  
Port 5: 0, primary, BRI  
Port 6: 0, primary, T1/E1  
Port 7: 0, primary, T1/E1  
Port 8: 0, primary, T1/E1
```

The following test will change the state of all relays from Primary to Secondary. Then it will change the state of all relays from Secondary to Primary. Lastly, it will change the state of each relay, one at a time, and verify that the state change was successful. Execute the following command to test relay state changes for the R-Series unit.

```
# ./rtest.sh tests /dev/rseries [#]
```

Output similar to the following is normal after executing this command.

```
R-Series hardware is detected!  
Executing these tests will disconnect any in  
progress calls!  
Type 'YES' to continue
```

If you wish to proceed, you must type YES in all upper-case. Output similar to the following is normal after pressing Enter.

```
Getting control and setting all ports to primary  
  
Getting control and setting all ports to secondary  
  
Getting control and setting all ports to primary  
  
Switching relays one at a time  
  
Getting control and setting port 1 to  
secondary...Success!  
  
Getting control and setting port 1 to  
primary...Success!  
  
Getting control and setting port 2 to  
secondary...Success!  
  
Getting control and setting port 2 to  
primary...Success!
```

Getting control and setting port 3 to  
secondary...Success!

Getting control and setting port 3 to  
primary...Success!

Getting control and setting port 4 to  
secondary...Success!

Getting control and setting port 4 to  
primary...Success!

Getting control and setting port 5 to  
secondary...Success!

Getting control and setting port 5 to  
primary...Success!

Getting control and setting port 6 to  
secondary...Success!

Getting control and setting port 6 to  
primary...Success!

Getting control and setting port 7 to  
secondary...Success!

Getting control and setting port 7 to  
primary...Success!

Getting control and setting port 8 to  
secondary...Success!

Getting control and setting port 8 to  
primary...Success!

## Automatic Failover Configuration

This section describes a particular method for configuring an R-Series unit for automatic failover which is supported by Digium. This method provides automatic failover for the following situations.

- A software failure resulting in Asterisk no longer running.
- A hardware or software failure resulting in the host software no longer being able to communicate to the host software running on the other node.

The following components are continuously replicated between nodes.

- Asterisk configuration files, voicemails, AstDB, and logs

The following components are transferred from the active node to the standby node during an automatic failover.

- PSTN connections
- Floating IP address

**Note:** Applications and devices should reference the floating IP address to connect to the active node instead of the node's normal IP address. The floating IP address is shared between the primary and secondary node. The primary node will start off by listening on the floating IP address. The floating IP address will not be assigned on the secondary node during this time. In the event that the primary node fails, the cluster manager will automatically promote the secondary node and assign the floating IP address to it. Application connections will break and then reconnect to the floating IP address again, which points to the secondary node.

## Automatic Failover Scenario

In this scenario, a PBX has been deployed with two machines that are either identical, or sufficiently comparable such that either machine can act as the primary PBX at any given time. This scenario describes what happens when a fatal hardware failure is experienced on the machine acting as the primary node.

### Actors

- PSTN
- R-Series unit (digital version)
- PBX A
- PBX B

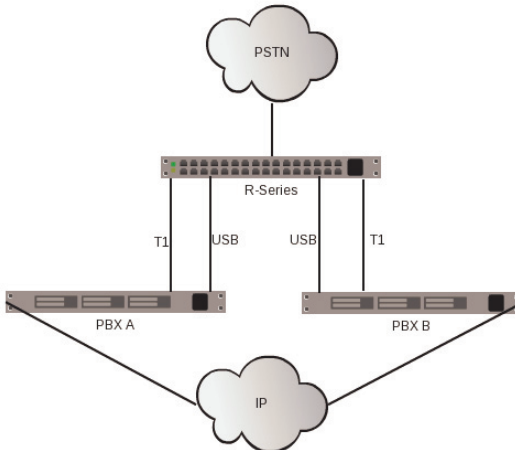

Figure 4: Automatic Failover Scenario

### Preconditions

- PBX A and PBX B are running the host software described in this section
- PBX A is acting as the primary node
  - Asterisk is running on PBX A
  - The R-Series unit has the T1(s) routed to PBX A
  - IP traffic is directed to PBX A
- PBX B is acting as a standby node for PBX A

### Trigger

- PBX A experiences a fatal hardware failure (loses power)

### General Flow

1. The host software on PBX B detects that PBX A has left the cluster
2. The host software on PBX B instructs the R-Series unit to direct the T1(s) to PBX B
3. The host software on PBX B activates the floating IP address locally
4. The host software on PBX B starts Asterisk
5. PBX A comes back online and rejoins the cluster as a standby for PBX B

### Host Software Components

The host software utilized for this method of automatic failover is comprised of Pacemaker, Corosync, and DRBD. A brief description of each of these components is listed below.

**Pacemaker** - *“Pacemaker is an Open Source, High Availability resource manager suitable for both small and large clusters. Hardware and application failures can result in prolonged downtime and impact your bottom line. In the event of a failure, resource managers like Pacemaker automatically initiate recovery and make sure your application is available from one of the remaining machines in the cluster. Your users may never even know there was a problem.”* - [www.clusterlabs.org](http://www.clusterlabs.org)

**Corosync** - *“The Corosync Cluster Engine is a Group Communication System with additional features for implementing high availability within applications. The project provides four C Application Programming Interface features:*

- *A closed process group communication model with virtual synchrony guarantees for creating replicated state machines.*
- *A simple availability manager that restarts the application process when it has failed.*
- *A configuration and statistics in-memory database that provides the ability to set, retrieve, and receive change notifications of information.*
- *A quorum system that notifies applications when quorum is achieved or lost.”* - [www.corosync.org](http://www.corosync.org)

**DRBD** - *“DRBD refers to block devices designed as a building block to form high availability (HA) clusters. This is done by mirroring a whole block device via an assigned network. DRBD can be understood as network based raid-1.”* - [www.drbd.org](http://www.drbd.org)

### **Failure Detection**

Pacemaker will be configured to periodically poll the resource agent in charge of the Asterisk process. One of the required interfaces of a resource agent is to be able to return the status of the resource.

The cluster messaging layer, Corosync, is in charge of determining cluster membership. If it loses contact with another node for any reason, it will decide that it has failed and failover will be initiated.

## Resource Management

Pacemaker manages resources in a cluster. A resource agent (RA) is a utility used by Pacemaker to take care of the details of managing a resource. For our purposes, Pacemaker is managing resources in a two-node cluster.

**Table 1: Resource Management**

<b>Requirement</b>	<b>Resource Agents</b>	<b>Description</b>
Asterisk	ocf:Digium:asterisk	Asterisk RA
Asterisk filesystem	ocf:linbit:drbd ocf:heartbeat:Filesystem	DRBD link to share a filesystem with configuration/log/spool directories and astdb.
PSTN connections	ocf:Digium:rseries	Handled via R-Series hardware
Floating IP address	ocf:heartbeat:IPaddr2	For VoIP connectivity

## Installation

This sections describes the installation procedure for each component used by this automatic failover method.

**Warning!** It is **CRITICAL** that the installation and configuration steps be followed in the order stated without any deviation. **Read the instructions in their entirety. Do not skip steps!**

**Warning!** We **highly recommend** that the hardware specifications and software versions on all nodes be identical.

**Warning!** We **highly recommend** using either the CentOS 5.6, Debian wheezy, or Ubuntu 10.04 (Lucid) Linux distribution on the **primary and secondary node**. Distributions with specific versions mentioned were used during Digium's testing of the automatic failover scenario described in this chapter.

**Warning!** We **highly recommend** that Asterisk **not** be installed on the **secondary node until after everything else is installed and configured**. It is acceptable for Asterisk to already have been installed on the primary node.

**Warning!** The automatic failover scenario described in this chapter requires that the Asterisk configuration be stored in flat files. This scenario will not work with an Asterisk configuration that is stored in Realtime (e.g. SQL database).

**Warning!** The automatic failover scenario described in this chapter supports an Asterisk setup that uses Asterisk Business Edition, Skype for Asterisk, Fax for Asterisk, G.729, HPEC, and any other Digium product that requires registration using the Digium register utility only when additional licenses have already been purchased and registered on the secondary node.

### DRBD

A USB flash drive will need to be installed on both the primary and secondary node for storing DRBD data. It is acceptable for the USB flash drives to not be of identical size as long as the smallest USB flash drive is at least 1GB in size. The USB flash drives must be large enough to store all data for Asterisk.

**Note:** USB flash drives are not provided with an R-Series unit. They must be purchased separately.

First, locate the device file that is created for each USB flash drive by executing **dmesg** on both the primary and secondary node. Look through the output of **dmesg** to locate the USB flash drive device file assignment.

Output identifying your USB flash drive device file may look similar to the following.

```
Vendor: 3System   Model: USB Flash Disk   Rev:
1.00
Type:   Direct-Access           ANSI
SCSI revision: 02
SCSI device sdb: 3989775 512-byte hdwr sectors
(2043 MB)
sdb: Write Protect is off
sdb: Mode Sense: 00 06 0c 76
sdb: assuming drive cache: write through
SCSI device sdb: 3989775 512-byte hdwr sectors
(2043 MB)
sdb: Write Protect is off
sdb: Mode Sense: 00 06 0c 76
sdb: assuming drive cache: write through
sdb: sdb1
sd 2:0:0:0: Attached scsi removable disk sdb
sd 2:0:0:0: Attached scsi generic sg1 type 0
```

The output shown above for this example identifies the USB flash drive being assigned a device file at */dev/sdb*.

The data on both USB flash drives must be “zeroed out” before initializing DRBD. Execute the following command on both the primary

and secondary node to “zero out” a USB flash drive and **irreversibly destroy all data on it.**

```
# dd if=/dev/zero of=/dev/[USB_flash_device] bs=1M
```

**Warning!** All data on this device will be permanently lost!

Depending on the size of the USB flash drive, completion of this command may take a long time (e.g. several minutes to several hours).

Output similar to the following is normal after executing this command.

```
dd: writing `/dev/sdb': No space left on device
1949+0 records in
1948+0 records out
2042764800 bytes (2.0 GB) copied, 633.794 seconds,
3.2 MB/s
```

USB flash drives of different sizes may be used. Regardless of whether or not they are the same size, partitions must be created on both USB flash drives that are of identical size and completely empty. The disk partition type must be Linux (0x83).

**Note:** It is highly recommended that the partition for DRBD be 1GB or larger.

Execute the following command on both the primary and secondary node to create a partition on the USB flash drive for DRBD.

```
fdisk /dev/[USB_flash_device]
```

Output similar to the following is normal after executing this command.

```
Device contains neither a valid DOS partition  
table, nor Sun, SGI or OSF disklabel  
Building a new DOS disklabel. Changes will remain  
in memory only,  
until you decide to write them. After that, of  
course, the previous  
content won't be recoverable.
```

```
Warning: invalid flag 0x0000 of partition table 4  
will be corrected by w(rite)
```

```
Command (m for help):
```

Issue the following commands to the *fdisk* application:

- Press **n** for new partition.
- Press **p** for primary partition.
- Press **1** for first partition number.
- Press **1** for first cylinder.
- If both USB flash drives are of identical size, press **Enter** for last cylinder. If they are of differing size, use a variation of the example “**+1024M**” for a 1,024MB (1GB) partition.
- Press **w** to write changes.

Output similar to the following is normal after executing these commands.

```
The partition table has been altered!
```

```
Calling ioctl() to re-read partition table.  
Syncing disks.
```

In most cases, the partition created on the USB flash drive will be assigned `/dev/[USB_flash_device]1`. This can be confirmed by executing the following command and verifying that the device file for the partition exists.

```
# ls /dev/[USB_flash_device]*
```

**Note:** The device file assigned to the USB flash drive's partition will be referenced at a later point in the manual. It is important to take note of this assignment.

Most Linux distributions should provide packages for DRBD. This package should be installed on both the primary and secondary node.

### Debian / Ubuntu

```
# apt-get install drbd8-utils
```

### Red Hat Enterprise Linux 5 / CentOS 5

```
# yum install drbd83 kmod-drbd83
```

**Note:** Do not start the DRBD service at this time.

## **Pacemaker & Corosync**

Like DRBD, packages should be provided by most Linux distributions for Pacemaker and Corosync. These packages should be installed on both the primary and secondary node.

### Debian / Ubuntu

```
# apt-get install corosync pacemaker
```

### Red Hat Enterprise Linux 5 / CentOS 5

**Note:** The clusterlabs.org repository requires a package that is in the EPEL repository. Digium recommends installing the individual package manually, rather than setting up the EPEL repo. Replace

*[arch]* with either *i386* or *x86\_64*, depending on your system's architecture.

```
# wget http://download.fedora.redhat.com/pub/epel/5/[arch]/libesmtp-1.0.4-5.el5.[arch].rpm
# rpm -Uvh libesmtp-*.rpm
# wget -O /etc/yum.repos.d/pacemaker.repo http://clusterlabs.org/rpm/epel-5/clusterlabs.repo
# yum install pacemaker corosync
```

**Note:** Do not start the Pacemaker or Corosync service at this time.

## Digium Resource Agents

Digium provides the source code for the resource agents for the R-Series unit and Asterisk, as well as sample configuration files for DRBD and Corosync. The sample configuration files will need to be modified, but should help you to get started. This software should be installed by executing the following commands on both the primary and secondary node.

```
# cd /usr/src/rseries-X.X.X/  
# make samples
```

**Note:** If you receive a message stating that the */etc/corosync/corosync.conf* file already exists and will not be replaced, you will need to backup the *corosync.conf* file located in the */etc/corosync* directory, and then manually copy the example *corosync.conf* file to the */etc/corosync* directory.

## Configuration

The configuration instructions in this section assume that the sample configuration files previously mentioned were installed.

**Note:** In the following examples, the node hostnames are specified as *astnode1* and *astnode2*. You must replace all instances of these with the hostnames of your nodes. This must exactly match the hostname of your nodes. An IP address cannot be used here. If the hostname is not set for the primary or secondary node, it may be set by executing **hostname [hostname]**.

## DRBD

DRBD works by acting as a middle-man between a filesystem and a disk. The filesystem lives on DRBD, which lives on a disk partition.

The DRBD package provided by some Linux distributions may not include a working */etc/drbd.conf* file. Ensure this file contains the following lines on both the primary and secondary node.

```
include "drbd.d/global_common.conf";
include "drbd.d/*.res";
```

The */etc/drbd.d/asterisk.res* file contains the configuration for the DRBD resource named *asterisk*. This configuration file must match on both the primary and secondary node. The following settings in this file must be modified to reflect your setup.

- The e-mail address on the **split-brain** line is where e-mail will be sent when DRBD detects a conflict that resulted in a split-brain (refer to DRBD project documentation for details on split-brain). The value

should be changed to an e-mail address that is monitored by an administrator. This requires that a Mail Transport Agent be installed, such as the one provided in the *libesmtp* package that was previously downloaded and installed. On many Linux distributions, a package named *sendmail* is also available.

- Replace all instances of the example **hostnames** with the hostnames of your nodes. This must exactly match the hostname of your nodes. An IP address cannot be used here. If the hostname is not set for either the primary or secondary node, it may be set by executing **hostname [hostname]**.
- The **device** lines must point to the DRBD device node. This will usually be */dev/drbd0*.
- The partition on the **disk** lines must refer to the partition that you created for DRBD on each node.
- The IP address on the **address** lines must be changed to the real (non-floating) IP addresses of each node.

Execute the following command on both the primary and secondary node to create metadata on disk for DRBD.

```
# drbdadm create-md asterisk
```

Output similar to the following is normal after executing this command.

```
--== Thank you for participating in the global
usage survey ===
The server's response is:

you are the 13356th user to install this version
Writing meta data...
initializing activity log
NOT initialized bitmap
New drbd meta data block successfully created.
success
```

**Note:** In order for DRBD to properly function, the firewall configuration (e.g. iptables) on both the primary and secondary node must allow incoming traffic on TCP port 7789 from the other node. If you are using iptables, you may flush all iptables rules by executing *iptables -F* after every reboot. Alternatively, you can permanently disable particular iptables rules by editing the iptables configuration file on each node. Depending on the Linux distribution, the iptables configuration file may be located at */etc/sysconfig/iptables* or */etc/network/interfaces*.

Then execute the following command on both the primary and secondary node to start the DRBD service.

```
# /etc/init.d/drbd start
```

Output similar to the following is normal after executing this command.

```
Starting DRBD resources: [  
asterisk  
Found valid meta data in the expected location,  
1027674112 bytes into /dev/sdb1.  
d(asterisk) n(asterisk) ]..
```

On only the primary node, generate a new UUID and create a new ext3 filesystem for DRBD. *[drbd\_device]* should usually be replaced with */dev/drbd0*.

**Note:** This should be done **only** on the primary node.

```
# drbdadm disconnect asterisk  
# drbdadm -- --clear-bitmap new-current-uuid  
asterisk  
# drbdadm -- --overwrite-data-of-peer primary  
asterisk  
# mkfs.ext3 -m0 [drbd_device]  
# drbdadm secondary asterisk  
# drbdadm detach asterisk  
# drbdadm up asterisk
```

Before proceeding to the next section, verify that DRBD file replication is functioning properly by executing the following commands.

### Primary Node

The following commands should be executed only on the primary node.

```
# drbdadm primary asterisk
# mkdir /mnt/asterisk
# mount -t ext3 [drbd_device] /mnt/asterisk
# cd /mnt/asterisk
# touch test
# ls
```

*Confirm that the file 'test' exists.*

```
# cd
# umount /mnt/asterisk
# drbdadm secondary asterisk
```

## Secondary Node

The following commands should be executed only on the secondary node.

```
# drbdadm primary asterisk
# mkdir /mnt/asterisk
# mount -t ext3 [drbd_device] /mnt/asterisk
# cd /mnt/asterisk
# ls
```

*Confirm that the file 'test' exists. If the 'test' file exists, file replication to the secondary node was successful. The 'test' file is the same 'test' that was created on the primary node.*

```
# cd
# umount /mnt/asterisk
# drbdadm secondary asterisk
```

### Asterisk & DAHDI

Since the configuration files for Asterisk are stored on the DRBD filesystem, this filesystem must be mounted in order to make changes. The filesystem is always mounted on the currently active node, which means that any changes will need to be made there. The changes will automatically be copied to the standby node, over the DRBD link.

The `createlinks.sh` script has been included which will easily create symbolic links from several Asterisk files and directories on the host filesystem to the appropriate places on the DRBD filesystem.

**Warning!** If these files and/or directories exist on the host filesystem and do not exist on the DRBD filesystem, they will be moved to the DRBD filesystem. It is highly recommended that these commands be executed before Asterisk is installed on the secondary node.

**Note:** For the sake of convenience, DAHDI will be installed and configured in this section. DAHDI configuration files are not replicated between nodes. In addition, DAHDI is not handled by this failover scenario.

## Primary Node

The following commands should be executed only on the primary node.

*[drbd\_device]* should usually be replaced with */dev/drbd0*.

```
# cd /usr/src/rseries-X.X.X
# drbdadm primary asterisk
# mount -t ext3 [drbd_device] /mnt/asterisk/
# ./createlinks.sh
```

If Asterisk is **not currently installed**, *createlinks.sh* will not generate any output after it is executed. If Asterisk is **currently installed**, output similar to the following is normal after executing *createlinks.sh*.

```
Moving /etc/asterisk/ to /mnt/asterisk/
etcasteriskdir/
mkdir: cannot create directory `~/mnt/asterisk/
etcasteriskdir': File exists
Moving /var/log/asterisk to /mnt/asterisk/logdir/
mkdir: cannot create directory `~/mnt/asterisk/
logdir': File exists
Moving /var/spool/asterisk/ to /mnt/asterisk/
spooldir/
mkdir: cannot create directory `~/mnt/asterisk/
spooldir': File exists
```

Before proceeding, verify that the *createlinks.sh* script successfully created the appropriate directories under */mnt/asterisk*. This can be accomplished by executing the following command.

```
# ls -alh /mnt/asterisk/
```

The output from this command should show that at least the following directories exist.

- *etcasteriskdir*
- *logdir*
- *spooldir*

**Note:** If Libpri, DAHDI, and Asterisk **are currently installed** on the primary node, the following steps will need to be completed on the primary node.

- If the Asterisk init script is installed (*/etc/init.d/asterisk*), it will need to be disabled in order to not conflict with the automatic failover configuration. This can be accomplished by executing **chkconfig --del asterisk** on Red Hat based distributions and **update-rc.d -f asterisk remove** on Debian based distributions.
- If the DAHDI init script is not already installed (*/etc/init.d/dahdi*), execute **make config** in the DAHDI source directory to install it.
- Execute **drbdadm secondary asterisk**.

**Note:** If Libpri, DAHDI, and Asterisk **are not currently** installed on the primary node, proceed with the steps below. Otherwise, skip these steps and proceed with the steps for the secondary node on page 69.

Download the latest version of Libpri. Substitute the version of Libpri for the X.X in the command-line below. Libpri is available for download from:

<http://downloads.asterisk.org/pub/telephony/libpri>

```
# wget http://downloads.asterisk.org/pub/telephony/  
libpri/libpri-X.X-current.tar.gz
```

**Note:** There is no correlation between the versioning of Libpri and Asterisk. The Libpri 1.4 branch will function with the Asterisk 1.6 and 1.8 branches.

Expand the downloaded file, compile its contents, and install the libraries. Substitute the version of Libpri for the X.X and X.X.X.X in the command-lines below.

```
# tar -zxvf libpri-X.X-current.tar.gz  
# cd libpri-X.X.X.X/  
# make  
# make install
```

Download the latest DAHDI drivers with tools. DAHDI is available for download from:

<http://downloads.asterisk.org/pub/telephony/dahdi-linux-complete>

```
# wget http://downloads.asterisk.org/pub/telephony/  
dahdi-linux-complete/dahdi-linux-complete-  
current.tar.gz
```

Expand the downloaded file, compile its contents, and install the drivers and tools. Substitute the version of DAHDI for the X.X.X in the command-lines below.

```
# tar -zxvf dahdi-linux-complete-current.tar.gz  
# cd dahdi-linux-complete-X.X.X+X.X.X  
# make  
# make install  
# make config
```

Then configure DAHDI according to the instructions provided in the product manual(s) for the installed Digium hardware. After configuring DAHDI, load the DAHDI kernel modules according to the instructions provided in the product manual(s) for the installed Digium hardware.

Download the latest release version of Asterisk. Substitute the version of Asterisk for the X.X.X in the command below. Asterisk is available for download from:

<http://downloads.asterisk.org/pub/telephony/asterisk>

```
# wget http://downloads.asterisk.org/pub/telephony/  
asterisk/asterisk-X.X.X-current.tar.gz
```

Expand the downloaded file, compile its contents, and install the application. Substitute the version of Asterisk for the X.X.X and X.X.X.X in the command-lines below.

```
# tar -zxvf asterisk-X.X.X-current.tar.gz  
# cd asterisk-X.X.X.X/  
# ./configure  
# make  
# make install
```

**Note:** Do **not** run “*make config*” for the Asterisk installation on the primary node. The automatic failover setup described in this chapter can start and stop Asterisk without the init script provided by “*make config*”. The init script may conflict with the automatic failover setup.

If this is the first Asterisk installation on this system, you should install the sample configuration files. To do this, run:

```
# make samples
```

**Note:** Running this command will overwrite, after making a backup copy, any older Asterisk configuration files that you have in the */etc/asterisk* directory.

If your installation has failed, it may be because you are missing one or more of the build dependencies, the kernel headers, or the development tools. Contact your reseller where the unit was purchased, or call Digium Technical Support at 1.256.428.6161 for assistance. Please refer to **Free Installation Support** on page 104 for additional information on how to obtain assistance from Digium Technical Support.

After installation is complete, execute the following commands.

```
# umount /mnt/asterisk/  
# drbdadm secondary asterisk
```

## **Secondary Node**

The following commands should be executed only on the secondary node.

*[drbd\_device]* should usually be replaced with */dev/drbd0*.

**Note:** If Asterisk is currently installed on the secondary node, the `createlinks.sh` script will fail. As stated previously on **page 46**, Asterisk should not already be installed on the secondary node, and software versions between the primary and secondary node should be identical.

```
# cd /usr/src/rseries-X.X.X
# drbdadm primary asterisk
# mount -t ext3 [drbd_device] /mnt/asterisk/
# ./createlinks.sh
```

Output similar to the following is normal after executing the last command.

```
mkdir: cannot create directory `~/mnt/asterisk/
etcasteriskdir': File exists
mkdir: cannot create directory `~/mnt/asterisk/
logdir': File exists
mkdir: cannot create directory `~/mnt/asterisk/
spooldir': File exists
```

Download the latest version of Libpri. Substitute the version of Libpri for the X.X in the command-line below. Libpri is available for download from:

<http://downloads.asterisk.org/pub/telephony/libpri>

```
# wget http://downloads.asterisk.org/pub/telephony/  
libpri/libpri-X.X-current.tar.gz
```

**Note:** There is no correlation between the versioning of Libpri and Asterisk. The Libpri 1.4 branch will function with the Asterisk 1.6 and 1.8 branches.

Expand the downloaded file, compile its contents, and install the libraries. Substitute the version of Libpri for the X.X and X.X.X.X in the command-lines below.

```
# tar -zxvf libpri-X.X-current.tar.gz  
# cd libpri-X.X.X.X/  
# make  
# make install
```

Download the latest DAHDI drivers with tools. DAHDI is available for download from:

<http://downloads.asterisk.org/pub/telephony/dahdi-linux-complete>

```
# wget http://downloads.asterisk.org/pub/telephony/  
dahdi-linux-complete/dahdi-linux-complete-  
current.tar.gz
```

Expand the downloaded file, compile its contents, and install the drivers and tools. Substitute the version of DAHDI for the X.X.X in the command-lines below.

```
# tar -zxvf dahdi-linux-complete-current.tar.gz
# cd dahdi-linux-complete-X.X.X+X.X.X
# make
# make install
# make config
```

Then configure DAHDI according to the instructions provided in the product manual(s) for the installed Digium hardware. After configuring DAHDI, load the DAHDI kernel modules according to the instructions provided in the product manual(s) for the installed Digium hardware.

Download the latest release version of Asterisk. Substitute the version of Asterisk for the X.X.X in the command below. Asterisk is available for download from:

<http://downloads.asterisk.org/pub/telephony/asterisk>

```
# wget http://downloads.asterisk.org/pub/telephony/
asterisk/asterisk-X.X.X-current.tar.gz
```

Expand the downloaded file, compile its contents, and install the application. Substitute the version of Asterisk for the X.X.X and X.X.X.X in the command-lines below.

```
# tar -zxvf asterisk-X.X.X-current.tar.gz
```

```
# cd asterisk-X.X.X.X/  
# ./configure  
# make  
# make install
```

**Note:** Do not run “*make samples*” or “*make config*” for the Asterisk installation on the secondary node.

If your installation has failed, it may be because you are missing one or more of the build dependencies, the kernel headers, or the development tools. Contact your reseller where the unit was purchased, or call Digium Technical Support at 1.256.428.6161 for assistance. Please refer to **Free Installation Support** on page 104 for additional information on how to obtain assistance from Digium Technical Support.

At this point, configuration changes can be made to Asterisk. Asterisk configuration changes will automatically be replicated between the primary and secondary node.

To complete the installation, execute the following commands.

```
# umount /mnt/asterisk/  
# drbdadm secondary asterisk
```

## Corosync

The */etc/corosync/corosync.conf* file contains the configuration for Corosync. This configuration file must match on both the primary and secondary nodes.

- The IP address on the **memberaddr** lines must be changed to the real IP addresses of each node.
- The network address on the **bindnetaddr** lines must be changed to the node's network address. If you are unsure of your network address, there are many free IP / subnet calculators available online.

The sample configuration should otherwise be suitable for most installations.

**Note:** On Debian-based systems, set the value of *START* to *yes* (i.e. “*START=yes*”) in the */etc/default/corosync* file on both the primary and secondary node in order for Corosync to start at boot time.

On both the primary and secondary node, start the Corosync service.

```
# /etc/init.d/corosync start
```

## **Pacemaker**

The sample configuration for Pacemaker is not automatically installed. In the R-Series source package, the *configs/pacemaker/* directory contains sample configuration files for Pacemaker. The *pacemaker.cfg* file is for single R-Series unit installations. The *pacemaker-multiple-rseries.cfg* file is for dual R-Series unit installations. The appropriate Pacemaker configuration file must be modified and loaded into a running Pacemaker installation. Any changes to the Pacemaker configuration will automatically be made on all nodes in the cluster.

**Note:** If more than two R-Series units are being installed, the *pacemaker.cfg* and *pacemaker-multiple-rseries.cfg* files can be compared using the *diff* command to determine what needs to be added to the *pacemaker-multiple-rseries.cfg* to support three or more units.

**Note:** Modifications to the Pacemaker configuration file should be made on only the primary node.

- At the top of the file, the values for **node** must be changed to reflect the name of your nodes.
- Under “*primitive Asterisk\_fs ocf:heartbeat:Filesystem*”, the value for **device** may need to be changed. Refer to Table 2 on page 76 to determine this.
- Under “*primitive ClusterIP ocf:heartbeat:IPaddr2*”, the values for **ip** and **cidr\_netmask** must be changed for the floating IP address. Refer to Table 2 on page 76 for more details.
- Under “*primitive GatewayStatus ocf:pacemaker:ping*”, the value for **host\_list** must be changed to an IP address or list of IP addresses to ping. Refer to Table 2 on page 76 for more details.
- Under “*primitive rseries ocf:Digium:rseries*”, the value for **tty** may need to be changed. Refer to Table 2 on page 76 to determine this.

The following table contains a list of important parameters and their descriptions for resource configuration.

**Table 2: Resource Configuration**

Resource Agent	Parameter	Required	Default	Description
ocf:Digium:asterisk				
	astbin	no	/usr/sbin/asterisk	Path to asterisk binary.
ocf:Digium:rseries				
	rctl	no	/usr/sbin/rctl	Path to rctl (R-Series control) binary.
	tty	no	/dev/rseries0	Path to the rseries / ttyUSB device node of the R-Series unit. The value of this setting must be the same on all nodes. It may be possible to determine the correct ttyUSB value by examining the output after executing " <i>dmesg   grep cp210x</i> ".
	deviceid	no	0	Sanity check for ensuring we're acting on the correct unit. Not yet implemented.
ocf:pacemaker:ping				
	host_list	yes		List of IP addresses to ping. Recommended setting: IP address of gateway
	multiplier	yes		Score multiplier. Recommended setting: 100
ocf:heartbeat:IPAddr2				

**Table 2: Resource Configuration**

Resource Agent	Parameter	Required	Default	Description
	ip	yes		This is the floating address that devices (e.g. SIP phones) would use to connect to Asterisk. This should be an IP address which is not already assigned to an Ethernet device on the primary or secondary nodes. The value of this setting must be the same on all nodes. Example, 192.168.50.210.
	cidr_netmask	yes		Netmask in CIDR format. For a netmask of 255.255.255.0, use "24". If you are unsure of the netmask, there are many free IP / subnet calculators available online.
ocf:linbit:drbd				
	drbd_resource	yes		Name of resource defined in DRBD configuration. Sample config uses "asterisk".
ocf:heartbeat:Filesystem				
	device	yes		Device node for DRBD resource. Sample config uses /dev/drbd/by-res/asterisk. This may need to be changed to /dev/drbd0 on some Linux distributions. The value of this setting must be the same on all nodes.
	directory	yes		Directory on which to mount DRBD filesystem. Sample config uses /mnt/asterisk/
	fstype	yes		DRBD filesystem type. Sample config uses ext3

After making the necessary changes, load the configuration into Pacemaker by executing the following commands on only the primary node. Substitute *pacemaker.cfg* for *pacemaker-multiple-rseries.cfg* if this is for a dual R-Series unit installation.

**Note:** The following commands should be executed only once.

```
# cd /usr/src/rseries-X.X.X
# crm configure load update configs/pacemaker/
pacemaker.cfg
```

Output similar to the following is normal after executing the last command.

```
INFO: building help index
WARNING: Asterisk_drbd: default timeout 20s for
start is smaller than the advised 240
WARNING: Asterisk_drbd: default timeout 20s for
stop is smaller than the advised 100
WARNING: Asterisk_drbd: action monitor not
advertised in meta-data, it may not be supported by
the RA
WARNING: Asterisk_fs: default timeout 20s for start
is smaller than the advised 60
WARNING: Asterisk_fs: default timeout 20s for stop
is smaller than the advised 60
WARNING: GatewayStatus: default timeout 20s for
start is smaller than the advised 60
WARNING: GatewayStatus: specified timeout 10 for
monitor is smaller than the advised 60
```

You will need to wait a few moments for Pacemaker to fully initialize. Once initialization is complete, verify that the configuration settings from the Pacemaker configuration file successfully propagated to the secondary node. This can be accomplished by executing the following command from the secondary node.

```
# crm configure show
```

If propagation to the secondary node was successful, the Pacemaker configuration will be output to the console.

Everything required for automatic failover, including DAHDI and Asterisk, should be loaded and running. Automatic failover configuration is now complete for the R-Series unit.

The automatic failover configuration can be verified by performing the following test.

- Disconnect the Ethernet cable on the primary node.
- Wait 30 seconds.
- Verify that Asterisk is now running on the secondary node.
- If SIP phones were registered, verify that they are now functioning with the secondary node.
- Verify that an inbound call over the PSTN lines connected to the R-Series unit is successful.
- Reconnect the Ethernet cable on the primary node.
- Wait 30 seconds.
- Disconnect the Ethernet cable on the secondary node.
- Wait 30 seconds.
- Verify that Asterisk is now running on the primary node.
- If SIP phones were registered, verify that they are now functioning with the primary node.
- Verify that an inbound call over the PSTN lines connected to the R-Series unit is successful.

This confirms automatic failover to and from the primary and secondary node.

## Chapter 4

# Troubleshooting

---

This chapter provides information regarding troubleshooting tools, frequently asked questions, and possible resolutions as identified by Digium Technical Support. Multiple resources are available to obtain more information about Asterisk and Digium products. Please visit both [www.digium.com](http://www.digium.com) and [www.asterisk.org](http://www.asterisk.org) for more information.

## Terminal Emulation Program Setup

A terminal emulation program can be used to configure and view the status of an R-Series unit. Minicom is a popular command-line terminal emulation program that is available for many Unix-like operating systems. Picocom is a popular alternative to Minicom. This section covers the use of a terminal emulation program to connect to the R-Series unit. Configuration of terminal emulation options not mentioned in this manual and instructions for installing a terminal emulation program are beyond the scope of this manual. Please refer to your operating system and program specific documentation for additional information.

In order to connect to the ASCII menu on the R-Series unit, a terminal emulation program must be configured to communicate with the R-Series unit's serial device file using the following settings.

**Table 3: Terminal Emulation Settings**

<b>Option</b>	<b>Value</b>
Bits Per Second	115,200
Data Bits	8
Parity Bits	None (N)
Stop Bits	1
Hardware Flow Control	None
Software Flow Control	None
Emulation	VT102 or VT100

## Minicom Setup

The examples and screenshots shown below reflect that of Minicom version 2.1. Newer and older versions of Minicom may use different command-line arguments and menus.

In order to begin configuring Minicom, execute the following command.

```
# minicom -s -c on
```

**Note:** If your terminal does not support color, omit the “*-c on*” arguments.

You will be presented with the following menu.

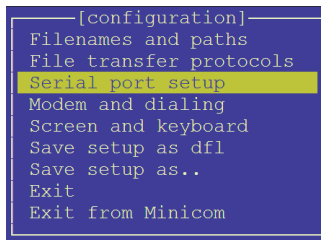
A screenshot of the Minicom main menu. The menu is displayed in a terminal window with a dark blue background and white text. The title of the menu is "[configuration]". The menu items are: "Filenames and paths", "File transfer protocols", "Serial port setup" (which is highlighted with a yellow background), "Modem and dialing", "Screen and keyboard", "Save setup as dfl", "Save setup as..", "Exit", and "Exit from Minicom".

```
[configuration]
Filenames and paths
File transfer protocols
Serial port setup
Modem and dialing
Screen and keyboard
Save setup as dfl
Save setup as..
Exit
Exit from Minicom
```

**Figure 5: Minicom Main Menu**

Use the arrow keys to navigate to “*Serial port setup*”. Then press *Enter*. You will be presented with the following menu.

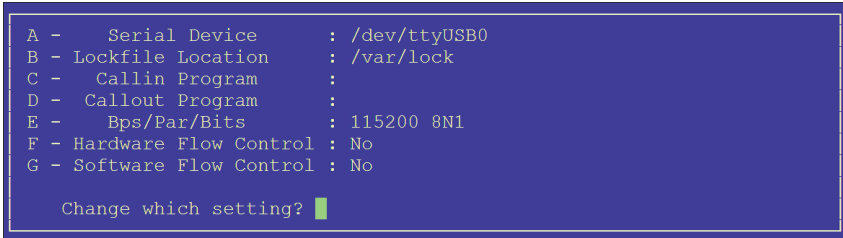
A screenshot of a terminal window with a dark blue background and white text. The text shows a configuration menu for a serial port. The options are listed as follows:

```
A - Serial Device      : /dev/ttyUSB0
B - Lockfile Location  : /var/lock
C - Callin Program    :
D - Callout Program   :
E - Bps/Par/Bits      : 115200 8N1
F - Hardware Flow Control : No
G - Software Flow Control : No
```

At the bottom of the menu, it says "Change which setting?" followed by a green cursor bar.

**Figure 6: Minicom Serial Port Setup**

Verify that the “*Serial Device*” setting specifies the serial device file associated with the R-Series unit that you wish to configure. Then verify that the other settings are configured to match the values shown in the screenshot above. Press *Esc* to return to the main menu.

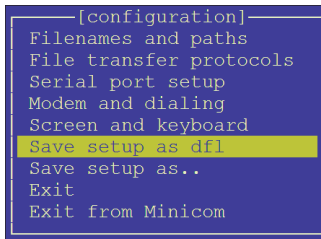
A screenshot of a terminal window with a dark blue background and white text. The text shows the main menu of the Minicom program. The options are listed as follows:

```
[configuration]
Filenames and paths
File transfer protocols
Serial port setup
Modem and dialing
Screen and keyboard
Save setup as dfl
Save setup as..
Exit
Exit from Minicom
```

The "Save setup as dfl" option is highlighted with a yellow background.

**Figure 7: Minicom Save as Default**

In order to save these changes as the default settings for Minicom, use the arrow keys to navigate to “*Save setup as dfl*”. Then press *Enter*. A confirmation box should appear that reads “*Confirmation saved*”.

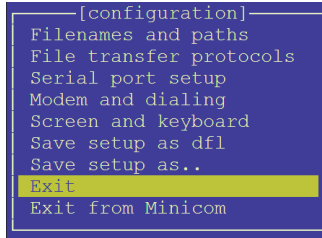
A screenshot of a terminal window showing the Minicom configuration menu. The menu is titled "[configuration]" and lists several options: "Filenames and paths", "File transfer protocols", "Serial port setup", "Modem and dialing", "Screen and keyboard", "Save setup as dfl", "Save setup as..", "Exit", and "Exit from Minicom". The "Exit" option is highlighted with a yellow background.

```
[configuration]
Filenames and paths
File transfer protocols
Serial port setup
Modem and dialing
Screen and keyboard
Save setup as dfl
Save setup as..
Exit
Exit from Minicom
```

**Figure 8: Minicom Exit**

If you wish to exit Minicom’s configuration menu and begin using Minicom, use the arrow keys to navigate to *Exit*. Then press *Enter*. Otherwise, select “*Exit from Minicom*” to completely exit Minicom.

After Minicom has been properly configured, you can simply connect to the R-Series unit by executing the following command.

```
# minicom -c on
```

**Note:** If your terminal does not support color, omit the “*-c on*” arguments.

In order to exit Minicom, the default command sequence requires you to press *Ctrl + a*, then *x*.

### Picocom Setup

If you wish to use Picocom to connect to the R-Series unit, execute the following command.

```
# picocom -b 115200 -f n -p n -d 8 /dev/rseries0
```

**Note:** If */dev/rseries0* is not the serial device file associated with your R-Series unit, that argument will need to be modified to reflect the correct serial device file.

In order to exit Picocom, the default command sequence requires you to press *Ctrl + a*, then *Ctrl + x*.

## ASCII Mode

ASCII Mode can be used to interact with and configure the R-Series unit. The ASCII Mode menu allows the configuration of a number of settings, some of which are dependent on the model of R-Series unit that is being configured.

If the *Console* USB port is used to connect to the R-Series unit, the ASCII Mode menu will be shown. Upon connecting to the R-Series unit from the *Primary* or *Secondary* USB ports, the R-Series unit may not display anything. If this is the case, the *Esc* key must be pressed three times in order to initialize ASCII Mode.

**Note:** If you enter ASCII Mode and the screen is still blank, press the *r* key to refresh the page.

Please refer to Table 1 for other keyboard commands in ASCII Mode.

**Table 1: ASCII Mode Keyboard Command List**

<b>Key</b>	<b>Action</b>
Arrow Up	Navigate Up
Arrow Down	Navigate Down
Arrow Left	Navigate Left
Arrow Right	Navigate Right
a	Navigate Left
s	Navigate Down

**Table 1: ASCII Mode Keyboard Command List**

<b>Key</b>	<b>Action</b>
w	Navigate Up
d	Navigate Right
Enter	Select
o	Toggle operational state
c	Apply Settings (save)
r	Refresh (revert unsaved changes)
xxx	Exit ASCII Mode menu

## Analog Configuration

The ASCII Mode Menu for an analog R-Series unit will look similar to the following illustration.

```

Digium R850  Firmware Version: 4
Serial Number: DM90127770001

Port      |Mode                Passthrough        State
All       |---            ---                ---
1         | T1/E1              disabled           Input to Primary
2         | T1/E1              disabled           Input to Primary
3         | T1/E1              disabled           Input to Primary
4         | T1/E1              disabled           Input to Primary
5         | T1/E1              disabled           Input to Primary
6         | T1/E1              disabled           Input to Primary
7         | T1/E1              disabled           Input to Primary
8         | T1/E1              disabled           Input to Primary

Arrow keys or a (left), d (right), w (up) or s (down) to navigate thru menu
r to refresh, <enter> to select, c to commit changes
o to toggle operational state, xxx to exit menu.

Operational Mode: complete
Control Port:
Primary heartbeat: <none>   Secondary heartbeat: <none>
Primary USB Power: ON      Secondary USB Power: OFF
Device ID: 0

```

**Figure 9: ASCII Mode Menu for Analog**

The model and firmware version of the R-Series unit are shown along the top of the ASCII Mode menu. The serial number is shown directly below that line. The 4 columns shown from left to right are for configuring Port, Mode, Passthrough, and State settings. The number of rows displayed will depend on how many ports are supported by the R-Series unit. The setting in the first configurable row of each column allows the same value to be applied across all ports for that column. Additional components of the ASCII Mode Menu are described below.

- **Port** - The number of this port on the unit
- **Mode** - The mode for this port
  - Analog
- **Passthrough** - Enable or disable Passthrough functionality for this port. Available only on specific R-Series models.
  - Note:** Passthrough is reserved for future use.
- **State** - The state for this port. An explanation of the states is provided at **State Descriptions** on page 105.
  - Input to Primary
  - Input to Secondary
- **Operational Mode** - The operational mode of the R-Series unit is displayed here.
  - simple - Reserved for future use.
  - complete - Default operational mode
- **Control Port** - Indicates whether the Primary or Secondary server is master.
- **Primary heartbeat** - Reserved for future use.
- **Secondary heartbeat** - Reserved for future use.
- **Primary USB Power** - Indicates whether the Primary server is on.
- **Secondary USB power** - Indicates whether the Secondary server is on.
- **Device ID** - Indicates the device ID dial assignment for the R-Series unit.

## Digital Configuration

The ASCII Mode Menu for a digital R-Series unit will look similar to the following illustration.

```

Digium R850 Firmware Version: 4
Serial Number: DM90127770001

Port      |Mode      Passthrough      State
All       |----
1         | T1/E1    disabled          Input to Primary
2         | T1/E1    disabled          Input to Primary
3         | T1/E1    disabled          Input to Primary
4         | T1/E1    disabled          Input to Primary
5         | T1/E1    disabled          Input to Primary
6         | T1/E1    disabled          Input to Primary
7         | T1/E1    disabled          Input to Primary
8         | T1/E1    disabled          Input to Primary

Arrow keys or a (left), d (right), w (up) or s (down) to navigate thru menu
r to refresh, <enter> to select, c to commit changes
o to toggle operational state, xxx to exit menu.

Operational Mode: complete
Control Port:
Primary heartbeat: <none>      Secondary heartbeat: <none>
Primary USB Power: ON         Secondary USB Power: OFF
Device ID: 0

```

**Figure 10: ASCII Mode Menu for Digital**

The model and firmware version of the R-Series unit are shown along the top of the ASCII Mode menu. The serial number is down directly below that line. The 4 columns shown from left to right are for configuring Port, Mode, Passthrough, and State settings. The number of rows displayed will depend on how many ports are supported by the R-Series unit. The setting in the first configurable row of each column allows the same value to be applied across all ports for that column. Additional components of the ASCII Mode Menu are described below.

- **Port** - The number of this port on the unit
- **Mode** - The mode for this port
  - T1/E1
  - BRI

**Note:** It is very important that the mode be properly configured. If incorrectly configured, the results would be unpredictable.
- **Passthrough** - Enable or disable Passthrough functionality for this port. Available only on specific R-Series models.

**Note:** Passthrough is reserved for future use.
- **State** - The state for this port. An explanation of the states is provided at **State Descriptions** on page 105.
  - Input to Primary
  - Input to Secondary
  - Loopback (T1/E1 mode only)
- **Operational Mode** - The operational mode of the R-Series unit is displayed here.
  - simple - Reserved for future use.
  - complete - Default operational mode
- **Control Port** - Indicates whether the Primary or Secondary server is master.
- **Primary heartbeat** - Reserved for future use.
- **Secondary heartbeat** - Reserved for future use.
- **Primary USB Power** - Indicates whether the Primary server is on.
- **Secondary USB power** - Indicates whether the Secondary server is on.

- **Device ID** - Indicates the device ID dial assignment for the R-Series unit.

## R-Series Command-line Utility

The name of the R-Series command-line utility is *rctl*. The syntax for *rctl* is shown below.

```
rctl [-d] [-p port[,port[,port[,...]]] | all] [-s
switchid] [-t device] [-w]
```

**Table 2: R-Series Command-line Utility**

Option	Description
-d	Enable debug mode
-p	Comma-delimited list of telephony ports (or 'all') to use for get/set operations
-t	Path to rseries / ttyUSB device node.
-w	Watch for all events/responses.
--get-firmware-version	Read firmware version
--get-serial-number	Read serial number
--get-product-number	Read product number/SKU.
--get-port-count	Read number of telephony ports on unit
--get-current-ctlport	Read USB port # from which the request was made
--get-master-ctlport	Read # of the USB port that is currently in master mode

**Table 2: R-Series Command-line Utility**

<b>Option</b>	<b>Description</b>
--get-id-switch	Rotary switch ID of the unit. See -s
--update-firmware	Update R-Series firmware. Must specify firmware filename.
--get-watchdog	Read timer settings for watchdog.
--set-watchdog	Set timer for watchdog. 0 to disable.
--ping-watchdog	Notify the watchdog that the host is still alive
--control-request	Request control of the unit. Required to modify USB port settings. See --get-master-ctlport
--control-release	Release control of the unit
--get-port-status	Read telephony port status
--set-port-status	Set telephony port status. Status can be 0/'primary' or 1/'secondary'.

A few examples of how to use the *rctl* utility are provided below.

Get firmware version:

```
# ./rctl -t /dev/rseries0 --get-firmware-version  
Firmware version: 2
```

Get serial number:

```
# ./rctl -t /dev/rseries0 --get-serial-number  
Serial number: dm96132120003
```

Get port count:

```
# ./rctl -t /dev/rseries0 --get-port-count  
Ports: 8
```

Get product name:

```
# ./rctl -t /dev/rseries0 --get-product-number  
Product number: R850
```

## Firmware Update

If an R-Series unit is behaving unexpectedly, its firmware may need to be updated. Please contact Digium Technical Support to obtain the latest R-Series firmware image. The firmware update must be performed using the *Primary* port on the R-Series unit. It is recommended to reference the ttyUSB device assignment of the R-Series unit when performing a firmware update. The R-Series firmware may be updated by executing the following commands.

```
# cd /usr/src/rseries-X.X.X/  
# rctl -t /dev/ttyUSB[#] --update-firmware  
[firmware_image]
```

**Warning!** Do not disconnect power during the firmware update process. The firmware update process may take a few minutes to complete.

The Status LED on the front of the R-Series unit will blink during the firmware update process.

Output similar to the following is normal after executing the last command.

```
Firmware stage1 completed successfully.  
Firmware stage2 completed successfully.  
Synching...  
Confirmed  
Synchronized  
Executing at address 0xd100
```

There is no need to power cycle the R-Series unit after a firmware update. You can verify that the firmware update was successful by executing the following command and examining the output.

```
# ./rtest.sh info /dev/rseries [#]
```

## Frequently Asked Questions

### **Why does the R-Series unit make an audible clicking sound when the state of a port changes?**

This is completely normal. This happens because mechanical relays are used in the R-Series unit.

### **What is the minimum version of the Linux kernel that supports the R-Series units?**

Linux kernel 2.6.12 and newer include the *cp2101* driver which is required by the R-Series units.

### **Can I connect to a USB port on an R-Series unit from Microsoft Windows?**

Yes, this is possible. Keep in mind that this method is not supported by Digium. You will need to install the CP210x USB to UART Bridge Virtual COM Port (VCP) drivers which are freely available from <http://www.silabs.com/products/mcu/Pages/USBtoUARTBridgeVCPDrivers.aspx>. You can determine the R-Series unit's COM port assignment by searching for it in the Windows Device Manager. In addition, PuTTY is a terminal emulation program which is freely available from <http://www.chiark.greenend.org.uk/~sgtatham/putty/>. Please refer to the documentation provided by the maintainers of those projects for further assistance.

### What do the colors of the *Device Status LED* indicate?

- **Solid Green** - All signals are routed from *Input* to *Primary*.
- **Solid Green for 2 seconds, followed by *N* 500ms flashes on and *N* 500 ms flashes off, where *N* is the number of ports on the R-Series unit** - Signal routing is mixed between *Primary* and *Secondary*. Each of the *N* flashes will be green if the port is routed to *Primary*, or Amber if the port is routed to *Secondary*.
- **Solid Amber** - All signals are routed from *Input* to *Secondary*.
- **Flashing Red** - Firmware is being updated.
- **Solid Red** - Firmware is corrupted.

### What do the colors of the *Primary Status LED* indicate?

- **Green** - R-Series unit is receiving valid data or heartbeat packets from the *Primary PBX*.
- **Amber** - Heartbeats from the *Primary USB* port have ceased, but the heartbeat timeout has not been reached.
- **Red** - Power is present on the *Primary USB* port and no heartbeat is present.

### What do the colors of the *Secondary Status LED* indicate?

- **Green** - R-Series unit is receiving valid data or heartbeat packets from the *Secondary PBX*.
- **Amber** - Heartbeats from the *Secondary USB* port have ceased, but the heartbeat timeout has not been reached.
- **Red** - Power is present on the *Secondary USB* port and no heartbeat is present.

**What type of cable do I need for the RJ11 ports on an R-Series analog unit?**

A straight-through RJ11 cable is needed for connecting to the RJ11 ports on an R-Series analog unit.

**What type of cable do I need for the RJ45 ports on an R-Series digital unit?**

A straight-through RJ45 cable is needed for connecting to the RJ45 ports on an R-Series digital unit.

**Which analog and digital protocols are supported by the R-Series units?**

The R-Series units will passthrough any protocol that they receive. They are not protocol dependent.

### **Why is it so difficult to disconnect a USB cable from an R-Series unit?**

You may have to apply a decent amount of force to disconnect a USB cable from an R-Series unit. This is normal. The USB connectors used in the R-Series units are high-retention to help prevent accidental disconnection.

### **What is a floating IP address?**

See the note on **page 39** for an explanation of a floating IP address in regards to an R-Series unit.

### **There is a slight echo. How can I adjust the sound quality?**

An R-Series unit simply passes on whatever it receives, including any echo that may have been generated from either leg of the call. If you experience a slight echo from a line that is connected to an R-Series unit, please refer to the manual of the hardware product which is connected to the R-Series unit for troubleshooting information regarding echo.

### Where can I find answers to additional questions?

There are several places to inquire for more information about Asterisk Digium products:

1. Digium Technical Support (+1.256.428.6161), or Toll Free in the U.S. (+1.877.344.4861), is available 7am-8pm Central Time (GMT -6), Monday - Friday. Please refer to **Free Installation Support** on page 104 for additional information on how to obtain assistance from Digium Technical Support.
2. Asterisk users mailing list ([asterisk.org/lists.digium.com](http://asterisk.org/lists.digium.com)).
3. IRC channel **#asterisk** on ([irc.freenode.net](http://irc.freenode.net)).

### Free Installation Support

Digium hardware products include free installation support. In order to receive this support, register your Digium product using the serial number located on the serialization sticker of your Digium unit.

Steps to receive installation support:

1. Record your product serial number.
2. Register your product at <http://www.digium.com/register>.
3. E-mail Digium Support via [support@digium.com](mailto:support@digium.com), or telephone via +1.256.428.6000 or Toll-Free +1.877.DIGIUM.1.

**Note:** Digium does not provide support for unregistered products.

### Subscription Services Program

Digium is dedicated to supporting your Asterisk system by offering full technical support through our Subscription Services Program. Through this program, you can be at ease knowing that your business will always have access to the Asterisk experts. Pricing on Subscription Services may be obtained from your nearest reseller or you may call Digium Sales for referral to your nearest reseller at +1.256.428.6000 or send an e-mail to [sales@digium.com](mailto:sales@digium.com)

# Appendix A

## State Descriptions

---

This section describes the states supported by the R-Series units.

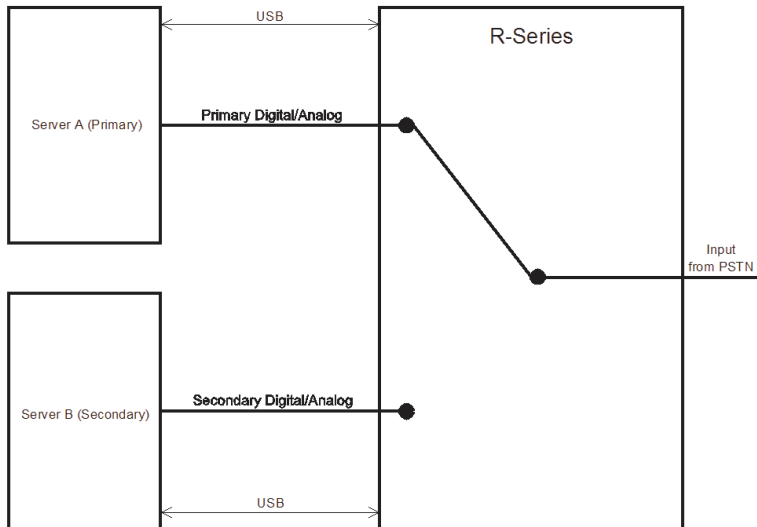

**Figure 1: Input to Primary State**

- **Input to Primary** - All signals are routed through the *Primary* ports. This is one of the two basic modes of operation and is available on all models.

**Note:** This state is the default mode of operation and is available on all models.

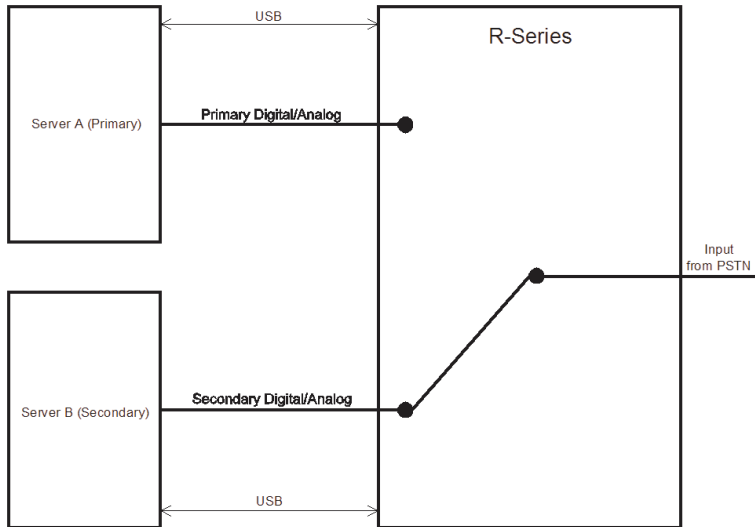

**Figure 2: Input to Secondary State**

- **Input to Secondary** - All signals are routed through the *Secondary* ports.

**Note:** This state is one of the two basic modes of operation and is available on all models.

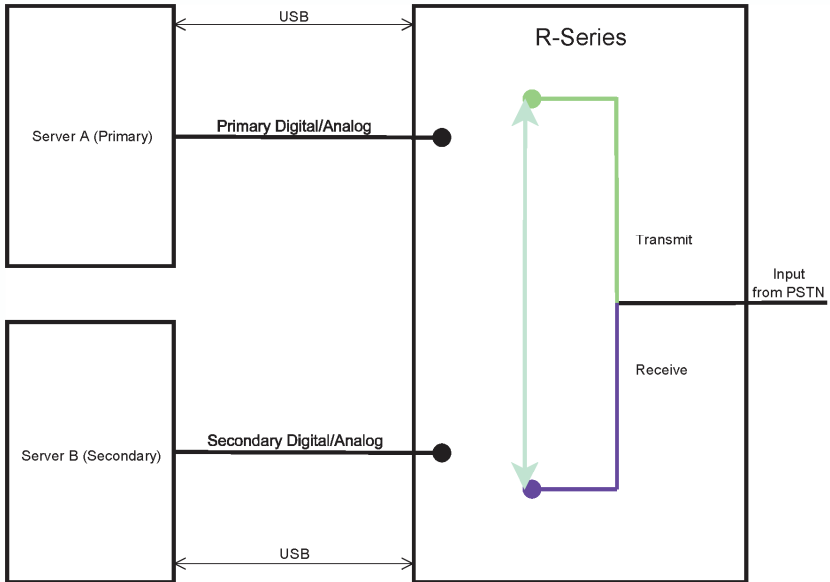

**Figure 3: Loopback State**

- **Loopback** - Carrier signals are looped back (receive to transmit).

**Note:** This state is reserved for digital models of the R-Series unit, and is not supported in BRI mode.

## Appendix B

### Pin Assignments

---

All RJ11 ports labeled *Input*, *Passthrough Input*, *Primary*, and *Secondary* on the R-Series unit are 6-pin. The pin assignments are identified in Table B-1.

Table B-1: RJ11 Port Connector

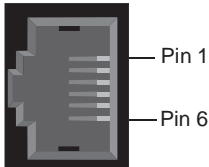
	Pin	Description
	1	Not used
	2	Not used
	3	Tip
	4	Ring
	5	Not used
	6	Not used

Certain analog models of the R-Series unit include a 50-pin RJ21 connector labeled as *Alternate Input*.

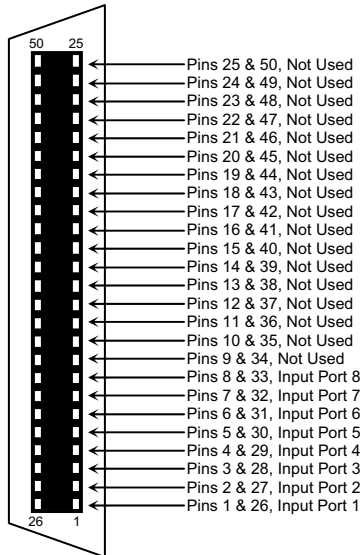
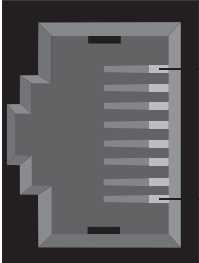

**Figure B-1: RJ21 Port Connector**

Pins 1-8 are ‘tip’ for Input ports 1-8. Pins 26-33 are ‘ring’ for Input ports 1-8.

All RJ45 ports labeled *Input*, *Passthrough Input*, *Primary*, and *Secondary* on the R-Series unit are 8-pin. The pin assignments are identified in Table B-1.

Table B-2: RJ45 Port Connector

	Pin	T1 / E1	BRI
	1	Rx+	Unused
	2	Rx-	Unused
	3	Unused	Tx+
	4	Tx+	Rx+
	5	Tx-	Rx-
	6	Unused	Tx-
	7	Unused	Unused
	8	Unused	Unused

# Appendix C

## License Agreement

---

### ***DIGIUM END-USER PURCHASE AND LICENSE AGREEMENT***

**August 2010**

#### **IMPORTANT – PLEASE READ CAREFULLY**

1. This Digium End-User Purchase and License Agreement (the "Agreement") is a legal agreement between Digium and its Affiliates (collectively referred to as "Digium") and the licensee, purchaser and end user respectively (hereinafter, "you", "You" or "your") of the Digium distribution media, software and related documentation (the "Software"), Digium services ("Services"), and any Digium computer electronics ("Hardware"), entitlements granted pursuant to a Subscription Agreement, and related manuals (collectively the "Products"). Affiliates means an entity which is (a) directly or indirectly controlling Digium; or (b) which is directly or indirectly owned or controlled by Digium. By downloading or installing the Software or installing the Hardware, you agree to and accept the terms and conditions of this Agreement. If you do not accept, or are not authorized to accept the terms and conditions of this Agreement, then you should not install the Software or Hardware and should remove any installed Software and Hardware from your computer.

**2. GRANT OF LICENSE.** Subject to the terms and conditions of this Agreement, Digium grants you a non-exclusive, non-sublicenseable, non-transferable license to use the Software for internal business purposes

and not for resale, sub license, leasing, or (except for those Products excluded in Section 2.1 of this Agreement) providing hosted services to third-parties. "Software" shall include any upgrades, updates, bug fixes or modified versions ("Upgrades") or backup copies of the Software supplied to you by Digium or an authorized reseller, provided you hold a valid license to the original Software and have paid any applicable fee for Upgrades. Notwithstanding the foregoing, you acknowledge that certain components of the Software may be covered by so-called "open source" software licenses ("Open Source Components"). Digium will provide a list of Open Source Components for a particular version of the Software upon your request. To the extent required by the licenses covering Open Source Components, the terms of such licenses will apply in lieu of the terms of this Agreement, and Digium hereby represents that only Open Source Components with licenses that intend to grant permissions no less broad than the license granted in this Section 2 are included in the Software. To the extent which the licenses applicable to Open Source Components prohibit any of the restrictions in this Agreement with respect to such Open Source Component, such restrictions will not apply . The Product Skype for Asterisk contains third party software that is licensed for use by Skype Software S.a.r.l under the terms of the Skype Business End User license at <http://www.skype.com/go/business.eula> for use with Skype communications products that are provided by Skype Communications S.a.r.l under the terms of the Skype Business Terms of Service at <http://www.skype.com/go/business.terms>. The Skype software is licensed, and the Skype products are provided, to end users for their own communication purposes only and any other use is strictly prohibited.

**Digium respects your privacy. Please read the following statement that applies to data collected by Digium through the Product Switchvox. The Product Switchvox collects a variety of information including but not limited to server and software configuration**

information and SIP Provider identities and reports that to Digium's server on a regular basis for the purpose of improving the performance of the Product Switchvox. This information may be stored by Digium perpetually. Digium may share and disclose the foregoing information in an aggregated form in order to describe our services to prospective and existing partners, advertisers, or other third parties, and for other lawful purposes. The aggregated information will not be linked to any personal information that can identify any individual person or company. The following information is excluded from being collected pursuant to the foregoing: call logs, call recording details, login and logout activity, extension details such as name, address, and password, SIP provider details such as username and password, phonebook entries for names and phone numbers, administrative-user information, and audio files. If you do not agree to allowing all information falling under the previously listed categories and excluding the exceptions to be collected you must indicate that by removing the checkmark from the allow box on the Product registration page of the Product Switchvox. You may notify Digium at any time pursuant to the foregoing that you do not agree to allow collection of the previously listed information. Failure to notify Digium that you do not agree to allow the collection of the listed information will be deemed consent to allow Digium to collect all listed information. The Product Switchvox SMB Trial also requests permission from Digium's server to continue running. If for any reason the Switchvox SMB Trial does not receive permission to continue running, then it will cease functioning. For any Product utilizing MP3 functionality (meaning the MPEG Layer-3 audio coding technology, which complies with the specifications and operating parameters established by the Joint Technical Committee of the International Standards Organization as

described in ISO/IEC IS 11172-3 and ISO/IEC IS 13818-3) supply of that Product does not convey a license nor imply any right to distribute MPEG Layer-3 compliant content created with that Product in revenue-generating broadcast systems (terrestrial, satellite, cable and/or other distribution channels), streaming applications (via Internet, intranets and/or other networks), other content distribution systems (pay-audio or audio-on-demand applications and the like) or on physical media (compact discs, digital versatile discs, semiconductor chips, hard drives, memory cards and the like). An independent license for such use is required. For details, please visit <http://mp3licensing.com>.

### **2.1 PRODUCTS EXCLUDED FROM HOSTED SERVICES RESTRICTION**

The following Products are excluded from the hosted services restriction of Section 2 of this Agreement. For purposes of clarification, You are free to use the Products in this Section 2.1 to provide hosted services to third parties.

G.729 for Asterisk

FAX for Asterisk

HPEC for Asterisk

**3. RESERVATION OF RIGHTS.** Except for the limited license rights expressly granted in this Agreement, Digium reserves all rights in and to the Software and any modifications thereto, including title, ownership, trademark, copyright, patent, trade secret and any other rights and interests. You will own only the Hardware (exclusive of Software embedded in the Hardware) and the physical media on which the Software and associated documentation are reproduced and distributed.

If you allow an existing Services or Subscription Agreement plan to lapse, you may be required to pay retroactively annual fees for all Products from the date of the lapse in order to reinstate such Services. Products that are provided or sold as demo or evaluation units, or are marked with the legend “For Evaluation Only” or a similar notation, are not authorized for commercial business use in production or deployment, but are made available only for demonstration or evaluation purposes, and may not be resold or transferred to any third party without prior written permission from Digium.

**4. EMERGENCY CALLS.** The Product Skype For Asterisk is excluded from this Section 4. Skype For Asterisk does not support any emergency calls and You acknowledge that if You are using Skype For Asterisk it is Your responsibility to purchase, separately from the Skype software and Skype Products, traditional wireless or fixed line telephone services that offer access to emergency services, as more explicitly referred to in the Skype Business End User License Agreement and the Skype Business Terms of Service. You understand and acknowledge that the Products may be used to implement, supplement, or replace telephone systems and telecommunications services, and that in some cases, certain government regulations may apply to their implementation or use; and compliance with such regulations is your sole responsibility. You understand and acknowledge that users of the system on which you install the Products may attempt to use that system to place emergency calls. You acknowledge and agree that: the Products must be properly configured for your system or application; that the nature of the Products and any networks they may operate upon allow many possible configurations; that such configuration may be beyond the scope of the documentation supplied with the Products; and that specialized experience and training may be required to properly configure the

Products. You acknowledge and agree that it is your sole responsibility to ensure that the Products and associated networks and systems are implemented and configured such that emergency calls are properly handled, and that any system or application based on the Products complies with all applicable laws and regulations. You acknowledge and agree that telephone and telecommunications systems can be complex and must be installed, implemented, and configured by the appropriate technically qualified personnel, and that you or your authorized agents have the qualifications necessary to properly implement and configure the Products to handle emergency calls, if applicable. You further acknowledge and agree that it is your sole and ongoing responsibility to ensure the proper operation of any emergency calling system based on the Products, including, but not limited to: initially and regularly testing the operation of the Products, including testing the operation with emergency services; notifying and training all users of any system on which the Products are installed how to use the system for emergency calls; and notifying such users of any and all limitations of your configuration and implementations of the Products and any network or system the Products are used on or with. By using the Products under this Agreement, you explicitly release Digium from any warranty, duty, liability, or obligation to train you or any users of your system regarding the proper configuration, operation, or use of the Products or any system or network they are used in conjunction with on which it is installed; to ensure that your configuration, implementation, or use of the Products provides for the proper handling or routing of emergency calls; or to ensure that your use of the Products is in compliance with any applicable laws and regulations.

### **5. LIMITATION OF LIABILITY.**

To the maximum extent permitted by law, Digium is not liable under any contract, negligence, strict liability or other legal or equitable theory for

any loss of use of the Products, inconvenience or indirect damages of any character, including but not limited to damages for copyright or patent infringement, whether special, incidental or consequential (including, but not limited to, loss of revenue or profit, work stoppage, computer failure or malfunction, failure of connected equipment or programs, loss of information or data or loss of goodwill) resulting from the use of the Products, relating to warranty service, or arising out of any breach of this Agreement, even if Digium has been advised of the possibility of such damages. The sole remedy for a breach of the foregoing limited warranty is repair, replacement or refund of the defective or non-conforming Product(s). The maximum liability of Digium under this Agreement is limited to the purchase price of the Product(s) which is the subject of the dispute. For purposes of clarification, to the maximum extent allowed by applicable law Digium is not liable in any amount for Excluded Product(s) as those Product(s) are provided at no charge. The foregoing express written warranties and remedies are exclusive and in lieu of any other warranties or remedies, express, implied or statutory.

## **6. WARRANTY.**

The terms under which Digium's Products are warranted are defined in the Digium Standard Warranty Policy, available on [www.digium.com](http://www.digium.com), the terms of which are included herein and incorporated by this reference.

### **6.1 WARRANTY EXCLUSIONS.**

For purposes of clarification, certain Digium Products and Product families are not covered by Digium's Standard Warranty Policy ("Excluded Products"). FOR THE EXCLUDED PRODUCTS, TO THE MAXIMUM EXTENT ALLOWED BY APPLICABLE LAW, NEITHER DIGIUM, NOR ITS THIRD-PARTY LICENSORS OR SUPPLIERS, NOR ITS DIRECTORS, OFFICERS, EMPLOYEES, OR AFFILIATES MAKE

ANY REPRESENTATIONS OR WARRANTIES OF ANY KIND TO ANY END USER, EITHER EXPRESS OR IMPLIED, WITH RESPECT TO THE PRODUCTS, INCLUDING, BUT NOT LIMITED TO WARRANTIES OR REPRESENTATIONS OF MERCHANTABILITY, FITNESS FOR A PARTICULAR PURPOSE, OR NON-INFRINGEMENT, EXCEPT TO THE EXTENT OTHERWISE SPECIFICALLY AGREED IN WRITING BY SUCH PERSON OR ENTITY. TO THE MAXIMUM EXTENT ALLOWED BY APPLICABLE LAW, IN NO EVENT SHALL DIGIUM, ITS THIRD PARTY LICENSORS OR SUPPLIERS, NOR ITS DIRECTORS, OFFICERS, EMPLOYEES, AFFILIATES OR LICENSORS BE LIABLE TO YOU FOR ANY DAMAGES OF ANY KIND, INCLUDING INCIDENTAL, CONSEQUENTIAL, OR ECONOMIC DAMAGE OR INJURY TO PROPERTY, LOST PROFITS OR LOST REVENUES, WHETHER BASED ON CONTRACT, TORT (INCLUDING NEGLIGENCE) OR OTHER THEORY AND REGARDLESS OF WHETHER SUCH PERSON OR ENTITY SHALL BE ADVISED OR HAVE REASON TO KNOW OF THE POSSIBILITY OF SUCH DAMAGES, EXCEPT TO THE EXTENT OTHERWISE AGREED IN WRITING BY SUCH PERSON OR ENTITY. The Excluded Products are defined in the follow subsections. All terms and conditions of this Agreement, apply to the Excluded Products as detailed in this Agreement.

### **6.1.1 PRODUCTS EXCLUDED FROM DIGIUM'S STANDARD WARRANTY POLICY**

The following Excluded Products are not covered by Digium's Standard Warranty Policy and Digium expressly disclaims any liability arising from use of such Excluded Products pursuant to Section 6.1. :

Asterisk Desktop Assistant (ADA)

FAX for Asterisk

G.729 for Asterisk

HPEC for Asterisk

**7. PROPRIETARY WORKS.** The Product(s) contain trademarks, trade secrets and/or copyrighted materials of Digium or its suppliers.

7.1 You agree not to reverse engineer, decompile, or disassemble the Software, nor defeat, bypass, remove or otherwise interfere with any licensing mechanism which may be provided in or with the Software, except to the extent such restriction is expressly prohibited by applicable law. You shall not disclose or make available such trade secrets or copyrighted material (including any information pertaining to any licensing mechanism which may be provided in or with the Software) in any form to any third party nor remove any trademark notices, copyright notices, or licensing terms from the Software or any components therein.

7.2 You will not (except with regard to fair use or nominative use) without Digium written consent, use the name, trademarks, trade names or logos of Digium, or the name of any product or service of Digium, in any manner. If Digium grants you a right to use the aforementioned, you will do so only in strict compliance with Digium trademark policies.

**8. TERMINATION.** This Agreement shall terminate upon either destruction of the Products or return of the Products by you to Digium. In the event of a breach of the scope of use permitted by the grant in Section 2, or if you do not comply with other materials terms and conditions of this Agreement, Digium shall have the right to immediately terminate this Agreement, in which case you must promptly destroy or return all Products to Digium. Notwithstanding the foregoing, the provisions of

Sections 5, 6, 7, 8, 9, 10, 11, 12 and 13 shall survive termination of this Agreement.

**9. EXPORT RESTRICTION.** You acknowledge that the Software, with the possible exception of certain third-party components, is of United States origin. The export and re-export of the Software is controlled by the United States Export Administration Regulations and such Software may not be exported or re-exported to Cuba, Iran, Iraq, Libya, North Korea, Sudan, Syria or any other country to which the United States embargoes goods. In addition, the Software may not be distributed to persons on the Table of Denial Orders, the Entity List, or the List of Specially Designated Nationals. By downloading or using a Digium Software Product, you are certifying that you are not a national of Cuba, Iran, Iraq, Libya, North Korea, Sudan, Syria or any other country to which the United States embargoes goods and that you are not a person on the Table of Denial Orders, the Entity List or the List of Specially Designated Nationals.

**10. TRANSFER AND ASSIGNMENT.** This Agreement and the rights and obligations under it are not assignable by you without the prior written approval of Digium, voluntarily or by operation of law. Any attempt by you to assign this Agreement without such approval shall be void. This Agreement shall inure to the benefit of the successors and assigns of Digium. Notwithstanding the foregoing, you may move the Software to different internal computers to the extent consistent with the scope of license you have purchased to the Software.

**11. U.S. GOVERNMENT USERS.** The Software and documentation qualify as “commercial items” as defined at 48 C.F.R. 2.101 and 48 C.F.R. 12.212. All Government users acquire the Software and

documentation with only those rights herein that apply to non-governmental customers of Digium.

**12. GOVERNING LAW AND JURISDICTION AND DISPUTE RESOLUTION.** This Agreement is to be construed in accordance with and governed by laws of the State of Alabama, excluding its conflict of law provisions. Digium and you agree to submit to the personal and exclusive jurisdiction of, and agree that venue is proper in, the Alabama State or Federal Courts located in the County of Madison, Alabama, for any such legal action or proceeding. Digium and you hereby expressly waive any right to a trial by jury and consent to a bench trial in the event of a dispute. Digium and you agree to attempt to resolve any dispute by direct communication between representatives of each party who are authorized to finally resolve the dispute. The parties agree to attempt to resolve the dispute within fourteen (14) days of notice of the dispute having been provided to the party not invoking this clause and agree not to resort to legal action, other than injunctions, during the fourteen day dispute resolution period. The United Nations Convention on International Sale of Goods, the application of which is expressly excluded, does not govern this Agreement.

**13. ENTIRE AGREEMENT.** This Agreement constitutes the entire understanding between the parties relating to the subject matter hereof and supersedes all prior writings, negotiations or understandings with respect thereto. The provisions of this Agreement shall take precedence over any conflicting terms in any subsequent purchase order, documentation or collateral. The parties agree that this Agreement may be executed electronically and that electronic copies of this Agreement shall be binding upon the parties. If any provision of this EULA is held to be void, invalid, unenforceable or illegal, the other provisions shall continue in full force and effect.

Digium EUPLA 08132010

## Appendix D

# Glossary and Acronyms

---

### **ACD**     *Automatic Call Distribution*

A technology that distributes incoming calls to a specific group of devices that are associated to agents. Asterisk's Queue application performs automatic call distribution.

### **ANSI**     *American National Standards Institute*

An organization which proposes and establishes standards for international communications.

### **asynchronous**

Not synchronized; not timed to an outside clock source. Transmission is controlled by start bits at the beginning and stop bits at the end of each character. Asynchronous communications are often found in internet access and remote office applications.

### **attenuation**

The dissipation of a transmitted signal's power as it travels over a wire.

### **bandwidth**

The capacity to carry traffic. Higher bandwidth indicates the ability to transfer more data in a given time period.

### **bit**

The smallest element of information in a digital system. A bit can be either a zero or a one.

### **bps**      *bits per second*

A measurement of transmission speed across a data connection.

### **BRI**

Basic Rate ISDN

### **broadband**

Broadband transmission shares the bandwidth of a particular medium (copper or fiber optic) to integrate multiple signals. The channels take up different frequencies on the cable, integrating voice, data, and video over one line.

### **channel**

A generic term for an individual data stream. Service providers can use multiplexing techniques to transmit multiple channels over a common medium.

### **Cat5**

Category of Performance for wiring and cabling. Cat 5 cabling support applications up to 100 MHz.

**Cat5E**

Category of Performance for wiring and cabling. Category 5 Enhanced wiring supports signal rates up to 100 MHz but adheres to stricter quality specifications.

**CLEC**     *Competitive Local Exchange Carrier*

A term for telephone companies established after the Telecommunications Act of 1996 deregulated the LECs. CLECs compete with ILECs to offer local service. See also *LEC* and *ILEC*.

**CO**         *Central Office*

The CO houses local switching equipment. All local access lines in a particular geographic area terminate at this facility (which is usually owned and operated by an ILEC).

**CPE**        *Customer Premises Equipment*

Terminal equipment which is connected to the telecommunications network and which resides within the home or office of the customer. This includes telephones, modems, terminals, routers, and television set-top boxes.

**DAHDI**     *Digium Asterisk Hardware Device Interface*

A telephony project dedicated to implementing a reasonable and affordable computer telephony platform into the world marketplace. In addition, the collective name for the Digium-provided drivers for Digium telephony interface products.

**DS0**     *Digital Signal, Level 0*

A voice grade channel of 64 kbps. The worldwide standard speed for digitizing voice conversation using PCM (Pulse Code Modulation).

**DS1**     *Digital Signal, Level 1*

1.544 Mbps in North America (T1) and Japan (J1) -up to 24 voice channels (DS0s), 2.048 Mbps in Europe (E1) - up to 32 voice channels (DS0s). DS1/T1/E1 lines are part of the PSTN.

**DS3**     *Digital Signal, Level 3*

T3 in North America and Japan, E3 in Europe. Up to 672 voice channels (DS0s). DS3/T3/E3 lines are not part of the PSTN.

**DTMF**     *Dual Tone Multi-Frequency*

Push-button or touch tone dialing.

**E1**

The European equivalent of North American T1, transmits data at 2.048 Mbps, up to 32 channels (DS0s).

**E3**

The European equivalent of North American T3, transmits data at 34.368 Mbps, up to 512 channels (DS0s). Equivalent to 16 E1 lines.

**EMI**     *Electromagnetic Interference*

Unwanted electrical noise.

**full duplex**

Data transmission in two directions simultaneously.

**FXO**     *Foreign Exchange Office*

Receives the ringing voltage from an FXS device. Outside lines are connected to FXO ports.

**FXS**     *Foreign Exchange Station*

Initiates and sends ringing voltage. Phones are connected to FXS ports.

**G.711**

A recommendation by the Telecommunication Standardization Sector (ITU-T) for an algorithm designed to transmit and receive mulaw PCM voice and A-law at a digital bit rate of 64 kbps.

**G.723.1**

A recommendation by the Telecommunication Standardization Sector (ITU-T) for an algorithm designed to transmit and receive audio at 6.3 kbps or 5.3 kbps.

**G.729a**

A recommendation by the Telecommunication Standardization Sector (ITU-T) for an algorithm designed to transmit and receive audio at 8 kbps.

**H.323**

A recommendation by the Telecommunication Standardization Sector (ITU-T) for multimedia communications over packet-based networks.

**HDLC**     *High-Level Data Link Control*

A bit-oriented synchronous data link layer protocol developed by the International Organization for Standardization (ISO).

**IAX**     *Inter-Asterisk eXchange*

The native VoIP protocol used by Asterisk. It is an IETF standard used to enable VoIP connections between Asterisk servers, and between servers and clients that also use the IAX protocol.

**iLBC**     *internet Low Bitrate Codec*

A free speech codec used for voice over IP. It is designed for narrow band speech with a payload bitrate of 13.33 kbps (frame length = 30ms) and 15.2 kbps (frame length = 20ms).

**ILEC**     *Incumbent Local Exchange Carrier*

The LECs that were the original carriers in the market prior to the entry of competition and therefore have the dominant position in the market.

**interface**

A point of contact between two systems, networks, or devices.

**ISO**     *International Standards Organization*

**IVR**     *Interactive Voice Menu*

An interactive technology that allows a telephone system to detect voice and keypad input.

**LED**     *Light-emitting Diode*

### **Linux**

A robust, feature-packed open source operating system based on Unix that remains freely available on the internet. It boasts dependability and offers a wide range of compatibility with hardware and software. Asterisk is supported exclusively on Linux.

### **loopback**

A state in which the transmit signal is reversed back as the receive signal, typically by a far end network element.

**MGCP**     *Media Gateway Control Protocol*

### **multiplexing**

Transmitting multiple signals over a single line or channel. FDM (frequency division multiplexing) and TDM (time division multiplexing) are the two most common methods. FDM separates signals by dividing the data onto different carrier frequencies, and TDM separates signals by interleaving bits one after the other.

**mux**     *multiplexer*

A device which transmits multiple signals over a single communications line or channel. See multiplexing.

### **node**

A terminal in a computer network.

**NT**      *Network Termination*

A device connecting the customer's telephone or data equipment to the local ISDN exchange carrier's line. NT devices are connected to TE devices.

**PBX**      *Private Branch Exchange*

A smaller version of a phone company's large central switching office. Example: Asterisk.

**PCI**      *peripheral component interconnect*

A standard bus used in most computers to connect peripheral devices.

**POP**      *Point of Presence*

The physical connection point between a network and a telephone network. A POP is usually a network node serving as the equivalent of a CO to a network service provider or an interexchange carrier.

**POTS**      *Plain Old Telephone Service*

The public switched telephone network (PSTN) is the network of the world's public circuit-switched telephone networks. Originally a network of fixed-line analog telephone systems, the PSTN is now almost entirely digital, and now includes mobile as well as fixed telephones.

**PPP**      *Point-to-Point Protocol*

Type of communications link that connects a single device to another single device, such as a remote terminal to a host computer.

**PRI**

Primary Rate ISDN

**PSTN**    *Public Switched Telephone Network*

A communications network which uses telephones to establish connections between two points. Also referred to as the dial network.

**PTMP**    *Point-to-Multipoint*

A connection where data is broadcast between more than two endpoints.

**PTP**      *Point-to-Point*

A connection restricted to two endpoints.

**PTT**      *Post, Telegraph, and Telephone*

The government agencies in many countries that traditionally operated and monopolized the public postal, telegraph, and telephone services.

**QoS**      *Quality of Service*

A set of quality requirements for telephone service.

**RBOC**    *Regional Bell Operating Companies*

The creation of Regional Bell Operating Companies were a result of AT&T's telephone monopoly being broken up in 1983.

**REN**      *Ringer Equivalence Number*

An arbitrary value which denotes the electrical load a telephone ringer has on a line.

## **RJ11**

A six-pin jack typically used for connecting telephones, modems, and fax machines in residential and business settings to PBX or the local telephone CO.

## **SIP**      *Session Initiation Protocol*

An IETF standard for setting up sessions between one or more clients. It is currently the leading signaling protocol for Voice over IP, gradually replacing H.323.

## **T1**

A dedicated digital carrier facility which transmits up to 24 voice channels (DS0s) and transmits data at 1.544 Mbps. Commonly used to carry traffic to and from private business networks and ISPs.

## **T3**

A dedicated digital carrier facility which consists of 28 T1 lines and transmits data at 44.736 Mbps. Equivalent to 672 voice channels (DS0s).

## **TDM**      *Time Division Multiplexer*

A device that supports simultaneous transmission of multiple data streams into a single high-speed data stream. TDM combines signals by interleaving bits one after the other.

## **TE**      *Terminal Equipment*

A device that is established as a point of termination of a communications circuit or channel. Terminal equipment comprises all customer premises equipment (CPE). TE devices are connected to NT devices.

### **telco**

A generic name which refers to the telephone companies throughout the world, including RBOCs, LECs, and PTTs.

### **tip and ring**

The standard termination on the two conductors of a telephone circuit; named after the physical appearance of the contact areas on the jack plug.

### **twisted pair**

Two copper wires commonly used for telephony and data communications. The wires are wrapped loosely around each other to minimize radio frequency interference or interference from other pairs in the same bundle.

**V**        *Volts*

**VoIP**     *Voice over Internet Protocol*

Technology used for transmitting voice traffic over a data network using the Internet Protocol.